

Operating Instructions

STEREO CONTROL AMPLIFIER

C-72

KU/CA

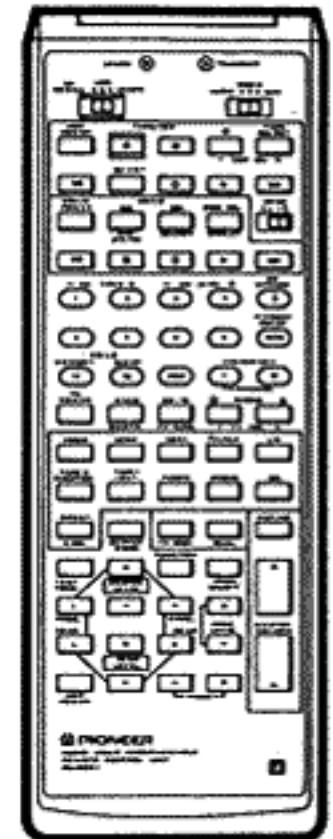
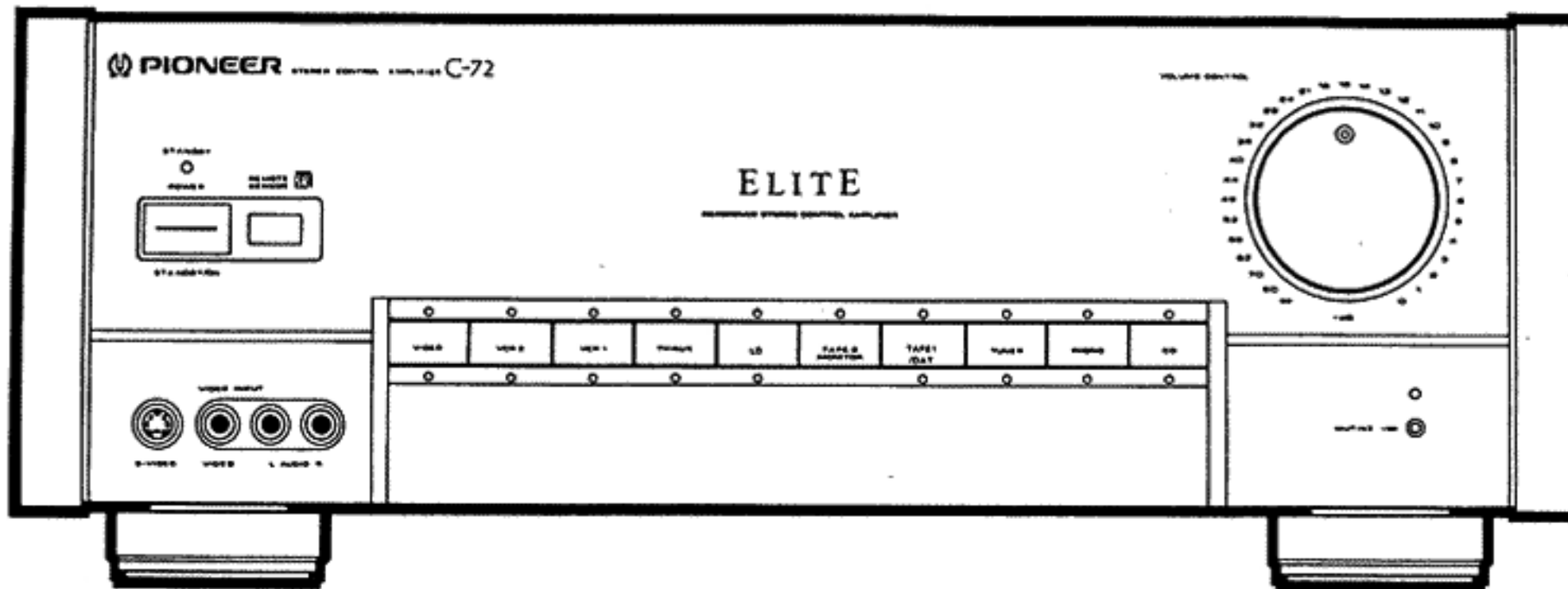

Thank you for buying this Pioneer product.
Please read through these operating instructions so you will know how to operate your model properly. After you have finished reading the instructions, put them away in a safe place for future reference.
In some countries or regions, the shape of the power plug and power outlet may sometimes differ from that shown in the explanatory drawings. However, the method of connecting and operating the unit is the same.

WARNING: TO PREVENT FIRE OR SHOCK HAZARD, DO NOT EXPOSE THIS APPLIANCE TO RAIN OR MOISTURE.

IMPORTANT NOTICE

[For U.S. and Canadian models]

The serial number for this equipment is located on the rear panel. Please write this serial number on your enclosed warranty card and keep it in a secure area. This is for your security.

[For Canadian model]

CAUTION: TO PREVENT ELECTRIC SHOCK DO NOT USE THIS (POLARIZED) PLUG WITH AN EXTENSION CORD, RECEPTACLE OR OTHER OUTLET UNLESS THE BLADES CAN BE FULLY INSERTED TO PREVENT BLADE EXPOSURE.

ATTENTION: POUR PREVENIR LES CHOCS ELECTRIQUES NE PAS UTILISER CETTE FICHE POLARISEE AVEC UN PROLONGATEUR UNE PRISE DE COURANT OU UNE AUTRE SORTIE DE COURANT, SAUF SI LES LAMES PEUVENT ETRE INSEREES A FOND SANS EN LAISSER AUCUNE PARTIE A DECOUVERT.

CONTENTS

BEFORE USING THE UNIT	3	PANEL FACILITIES	18
FEATURES	4	OPERATIONS 1 (Basic Operation)	21
PRECAUTIONS DURING USE	4	OPERATIONS 2 (Applications)	24
CONNECTIONS	5	TROUBLESHOOTING	26
HOW TO USE THE PROGRAMMABLE (LEARNING) REMOTE CONTROL UNIT	9	SPECIFICATIONS	28

IMPORTANT



The lightning flash with arrowhead, within an equilateral triangle, is intended to alert the user of the presence of uninsulated "dangerous voltage" within the product's enclosure that may be of sufficient magnitude to constitute a risk of electric shock to persons.

CAUTION
RISK OF ELECTRIC SHOCK
DO NOT OPEN

CAUTION:
TO PREVENT THE RISK OF ELECTRIC SHOCK, DO NOT REMOVE COVER (OR BACK). NO USER-SERVICEABLE PARTS INSIDE. REFER SERVICING TO QUALIFIED SERVICE PERSONNEL.



The exclamation point within an equilateral triangle is intended to alert the user of the presence of important operating and maintenance (servicing) instructions in the literature accompanying the appliance.

SAFETY INSTRUCTIONS

READ INSTRUCTIONS — All the safety and operating instructions should be read before the appliance is operated.

RETAIN INSTRUCTIONS — The operating instructions should be retained for future reference.

HEED WARNING — All warnings on the appliance and in the operating instructions should be adhered to.

FOLLOW INSTRUCTIONS — All operating and use instructions should be followed.

WATER AND MOISTURE — The appliance should not be used near water — for example, near a bathtub, washbowl, kitchen sink, laundry tub, in a wet basement, or near a swimming pool, etc.

LOCATION — The appliance should be installed in a stable location.

WALL OR CEILING MOUNTING — The appliance should not be mounted to a wall or ceiling.

VENTILATION — The appliance should be situated so that its location or position does not interfere with its proper ventilation. For example, the appliance should not be situated on a bed, sofa, rug, or similar surface that may block the ventilation openings; or, placed in a built-in installation, such as a bookcase or cabinet that may impede the flow of air through the ventilation openings.

HEAT — The appliance should be situated away from heat sources such as radiators, heat registers, stoves, or other appliances (including amplifiers) that produce heat.

POWER SOURCES — The appliance should be connected to a power supply only of the type described in the operating instructions or as marked on the appliance.

POWER-CORD PROTECTION — Power-supply cords should be routed so that they are not likely to be walked on or pinched by items placed upon or against them, paying particular attention to cords at plugs, convenience receptacles, and the point where they exit from the appliance.

POLARIZATION — If your purchased product is provided with a polarized power plug, please read the following instructions. This product is equipped with a polarized alternating current line plug (a plug having one blade wider than the other). This plug will fit into the power outlet only one way. This is a safety feature. If you are unable to insert the plug fully into the outlet, try reversing the plug. If the plug should still fail to fit, contact your electrician to replace your obsolete outlet. Do not defeat the safety purpose of the polarized plug.

CLEANING — The appliance should be cleaned only with a polishing cloth or a soft dry cloth. Never clean with furniture wax, benzene, insecticides or other volatile liquids since they may corrode the cabinet.

POWER LINES — An outdoor antenna should be located away from power lines.

NONUSE PERIODS — The power cord of the appliance should be unplugged from the outlet when left unused for a long period of time.

OBJECT AND LIQUID ENTRY — Care should be taken so that objects do not fall and liquids are not spilled into the enclosure through openings.

DAMAGE REQUIRING SERVICE — The appliance should be serviced by a Pioneer authorized service center or qualified service personnel when:

- The power-supply cord or the plug has been damaged; or
- Objects have fallen, or liquid has been spilled into the appliance; or
- The appliance has been exposed to rain; or
- The appliance does not appear to operate normally or exhibits a marked change in performance; or
- The appliance has been dropped; or the enclosure damaged.

SERVICING — The user should not attempt to service the appliance beyond that described in the operating instructions. For all other servicing, contact the nearest Pioneer authorized service center.

OUTDOOR ANTENNA GROUNDING — If an outside antenna is connected to the antenna terminal, be sure the antenna system is grounded so as to provide some protection against voltage surges and built up static charges.

In the U.S.A. section 810 of the National Electrical Code, ANSI/NFPA No. 70-1984, provides information with respect to proper grounding of the mast and supporting structure, grounding of the lead-in wire to an antenna discharge unit, size of grounding conductors, location of antenna discharge unit, connection to grounding electrodes, and requirements for the grounding electrode. See Fig. A.

CART — An appliance and cart combination should be moved with care. Quick stops, excessive force, and uneven surfaces may cause the appliance and cart combination to overturn.



NEC — NATIONAL ELECTRIC CODE

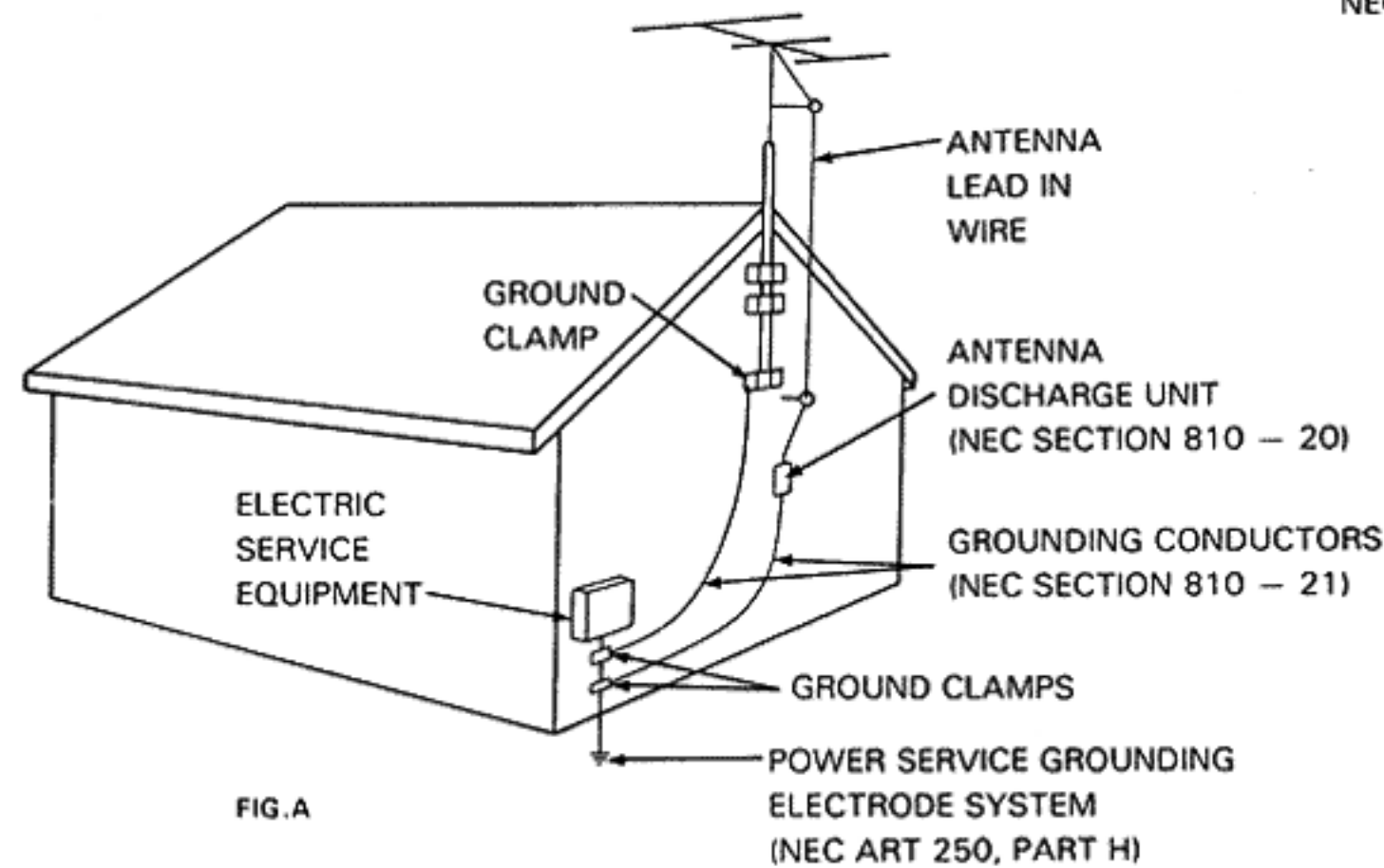

BEFORE USING THE UNIT

Accessories

• Remote Control Unit..... 1

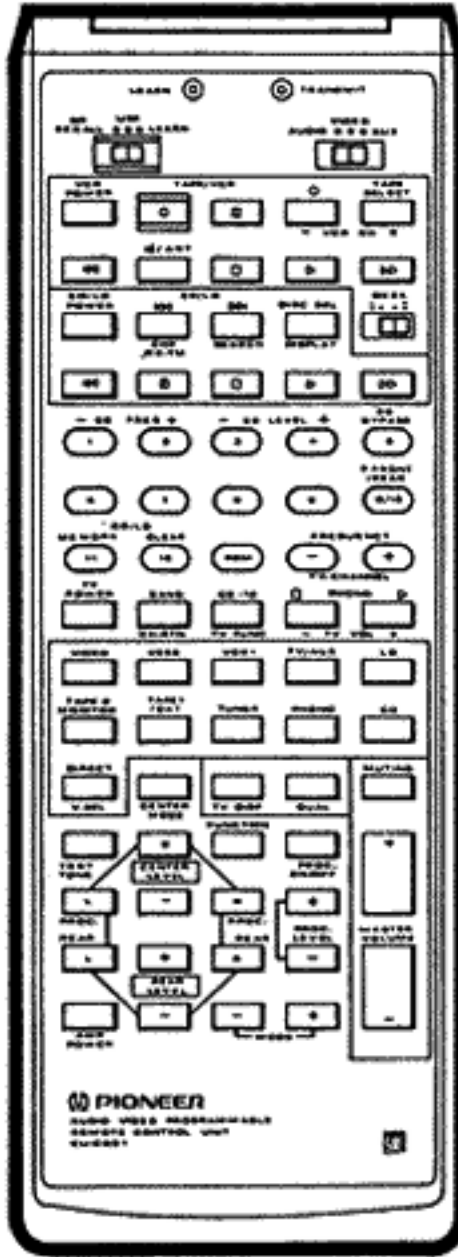

• Templates added 2

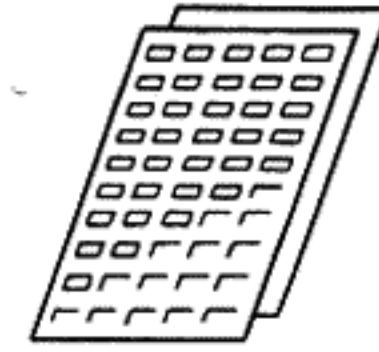

• Pin-Plug cord 1

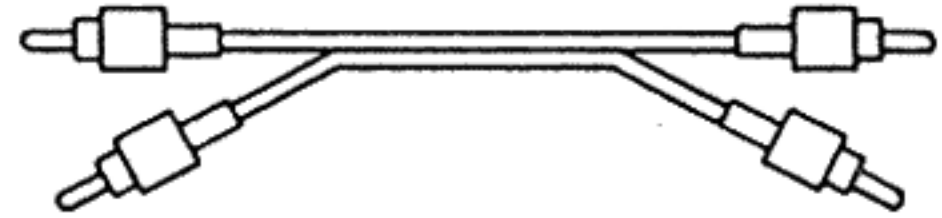

• Cushion spacer 2

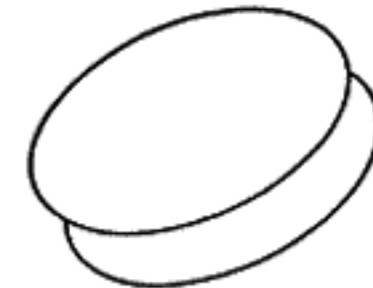

• "AAA" size IEC LR03 (AM-4) alkaline dry cell batteries..... 4

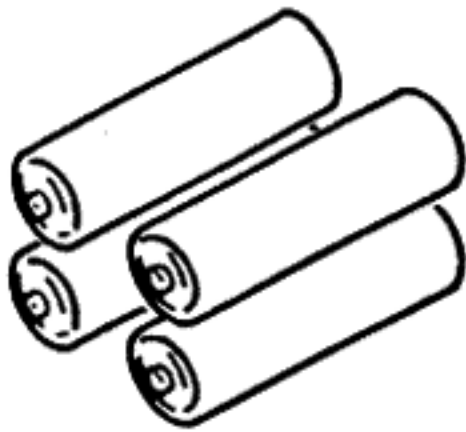

USING THE CUSHION SPACERS

If the set rattle, stick the cushion spacers to the bottom of the legs.

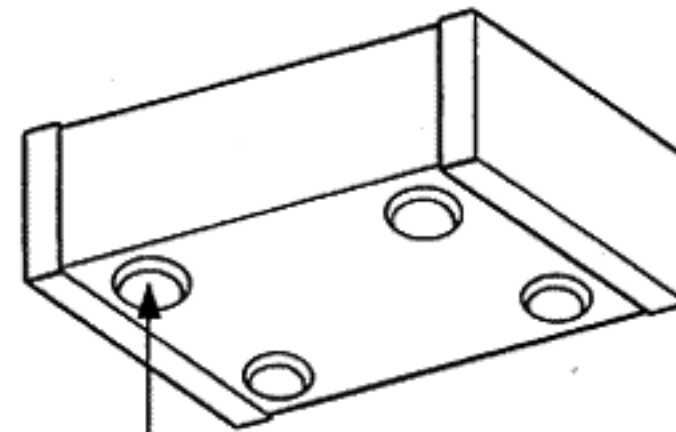

Peel off the backing and stick to the leg.

[For Canadian model]

This digital apparatus does not exceed the Class B limits for radio noise emissions from digital apparatus set out in the Radio Interference Regulations of the Canadian Department of Communications.

[Pour le modèle Canadien]

L'interférence, radioélectrique générée par cet appareil numérique de type B ne dépasse pas les limites énoncées dans le Règlement sur les perturbations radioélectriques, section appareil numérique, du Ministère des Communications.

INFORMATION TO USER [FOR U. S. MODEL]

This equipment generates and uses radio frequency energy and if not installed and used properly, that is, in strict accordance with the manufacturer's instructions, may cause interference to radio and television reception. It has been type tested and found to comply with the limits for a Class B computing device in accordance with the specifications in Subpart J of Part 15 of FCC Rules, which are designed to provide reasonable protection against such interference in a residential installation. However, there is no guarantee that interference will not occur in a particular installation.

If this equipment does cause interference to radio or television reception, which can be determined by turning the equipment off and on, the user is encouraged to try to correct the interference by one or more of the following measures:

- reorient the receiving antenna
- relocate this component with respect to the receiver
- move this component away from the receiver
- plug this component into a different outlet so that component and receiver are on different branch circuits.

If necessary, the user should consult the dealer or an experienced radio/television technician for additional suggestions. The user may find the following booklet prepared by the Federal Communications Commission helpful:

"How to Identify and Resolve Radio-TV Interference Problems"

This booklet is available from the US Government Printing Office, Washington, D.C., 20402, Stock No. 004-000-00345-4.

The above instructions apply only to units which will be operated in the United States.

FEATURES

ABUNDANT AV INPUTS

A total of five audio inputs, and five video inputs, with one video input on the front panel.

SUPPLIED PROGRAMMABLE REMOTE CONTROL UNIT FOR MORE CONVENIENT OPERATION

By using the program function, you can control other components (including other makers' components).

CLEAN GROUND TECHNOLOGY

Clean ground technology prevents noise on power line to flow to the signal ground line, permitting clean sound reproduction.

MINIMIZED SIGNAL PATH DESIGN

Relay and electronic signal switching keep the signal route as short as possible. By switching the Direct ON/OFF function ON, the signal bypasses any sound quality adjusting circuitry, giving you the pure, unaffected sound.

LOCAL POWER OFF FUNCTION

When not using video and phono inputs, turn the video power circuit and the phono equalizer power circuit off in order to prevent them from collecting noise during playback of other sources.

EQUIPPED WITH A FIXED-OUT TERMINAL FOR SURROUND PROCESSOR CONNECTION

TWO-TRANSFORMER MULTI-SUPPLY

The control power supply has its own transformer which is isolated from a second transformer having separate windings supplying the audio and video systems, so there is virtually no interference between them.

HIGH-QUALITY PARTS FOR HIGH-QUALITY SOUND

All parts used, including the newly developed motor-driven volume control, operational amp IC's, capacitors, resistors, printed circuit board and lead wires, were selected to assure high sound quality.

ALL-FUNCTION RECORDING SELECTOR

The recording selector is equipped to handle all audio and video inputs, so you can record from any source while playing another.

PRECAUTIONS DURING USE

LOCATION

Install the Control Amplifier in a well ventilated location where it will not be exposed to high temperature or humidity.

Do not install the Control Amplifier in a location which is exposed to direct rays of the sun, or near to hot appliances or radiators. Excessive heat can adversely affect the cabinet and internal components. Installation of the Control Amplifier in a damp or dusty environment may result in malfunction or accident. (Also avoid installation near cookers etc., where the Control Amplifier may be exposed to smoke from oil, steam or heat.)



PRECAUTIONS FOR INSTALLATION

To ensure optimum sound quality, observe the following precautions:

- This unit is heavy. Be sure to install it on a firm base which can support its weight. Also, to prevent the flow of cooling air from being blocked off, do not place the unit on soft material such as a carpet or cushion, or install it in a confined space. When installing the unit in a rack, provide adequate space around it to allow heat to dissipate.
- To prevent the control amplifier from picking up noise due to leakage flux from the power amplifier when the control amplifier and power amplifier are installed adjacent to each other, install the control amplifier on the right of the power amplifier. Also, if you install the control amplifier above or below the power amplifier, place a partition between them to separate them by at least 4-inch (10 cm) from each other.
- Install the unit on a level surface so that the feet of the unit are all touching the installation surface.

CONNECTIONS

AUDIO COMPONENT CONNECTIONS

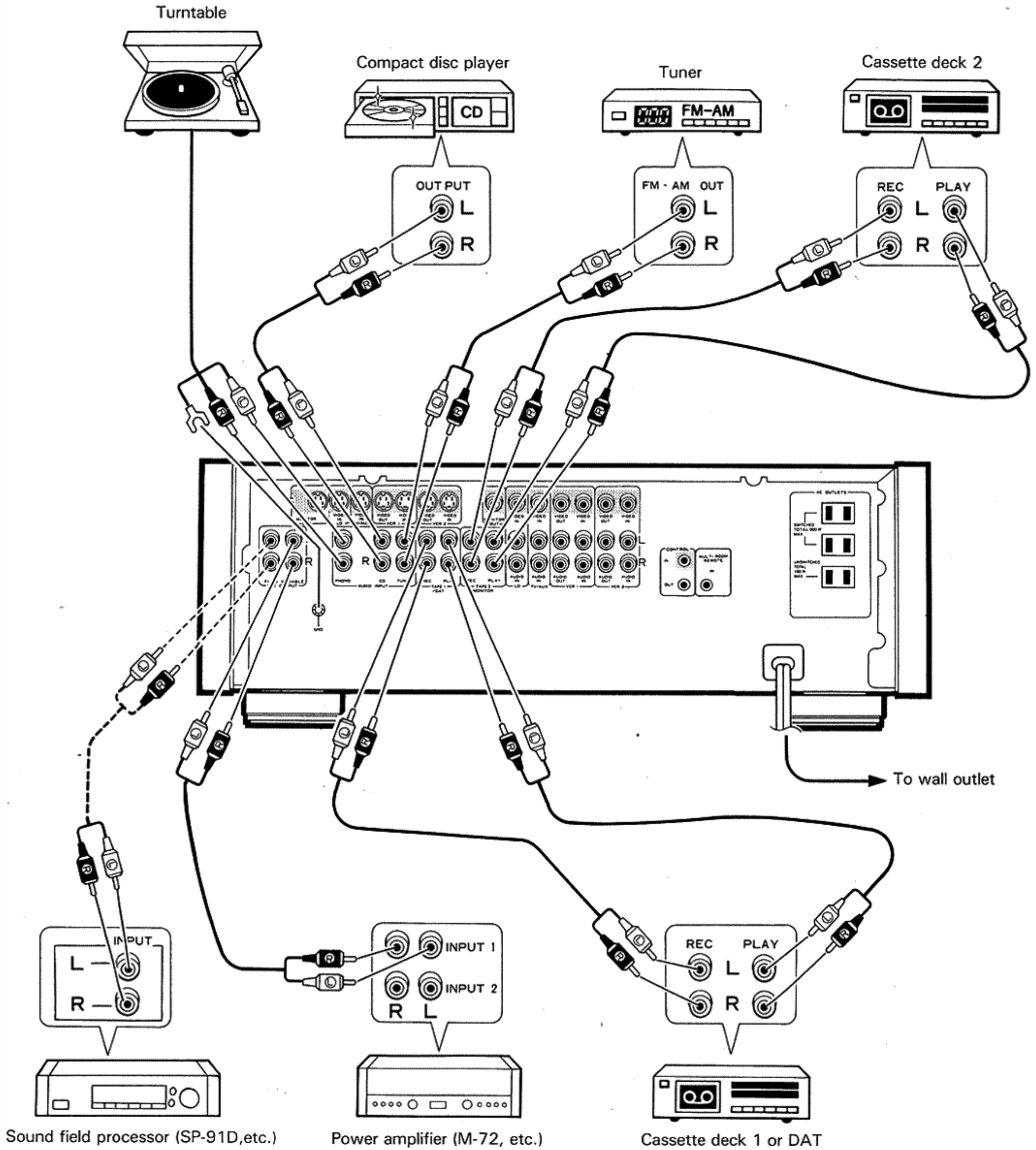

VIDEO COMPONENT CONNECTIONS I

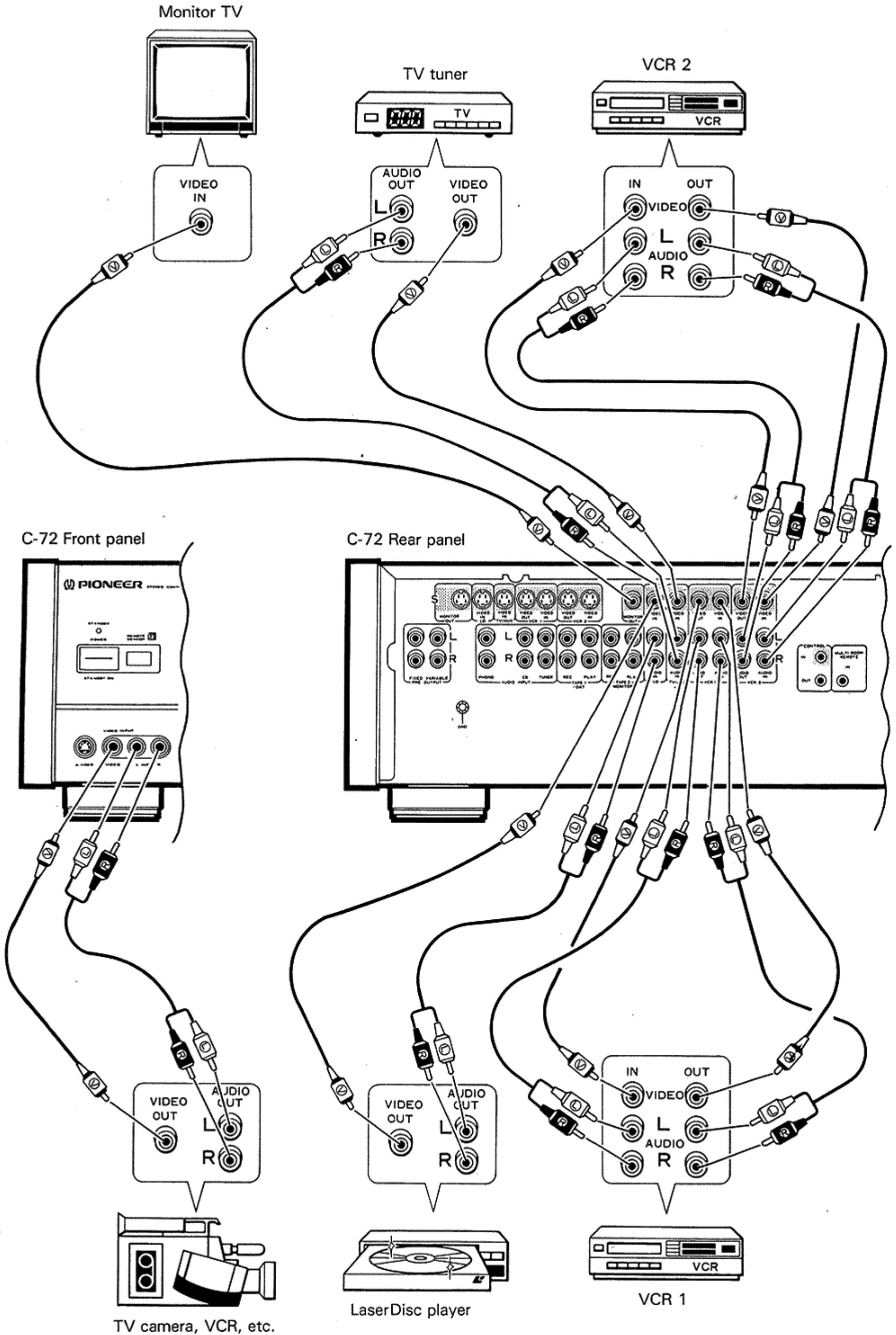

VIDEO COMPONENT CONNECTIONS II
(S type terminal)

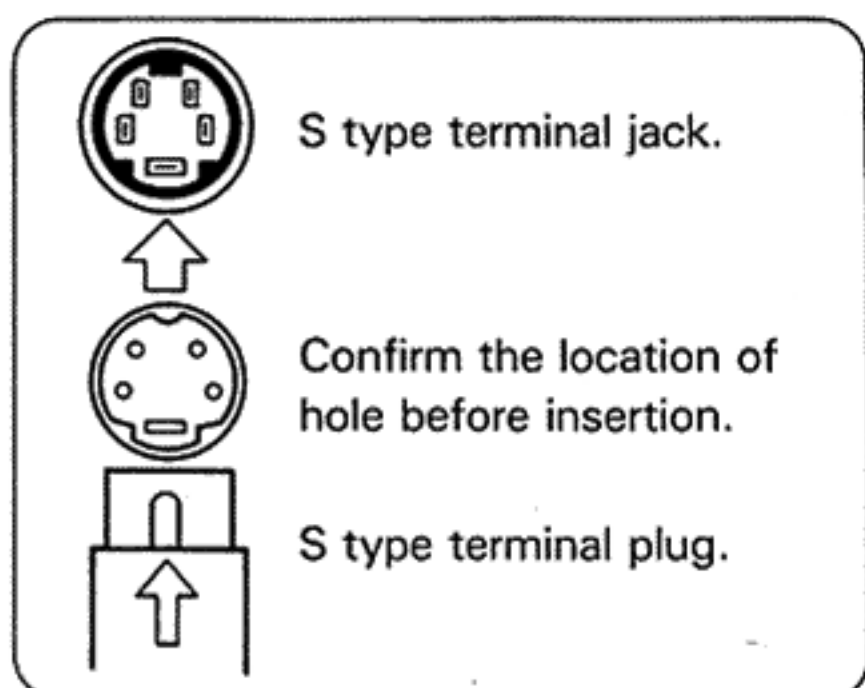
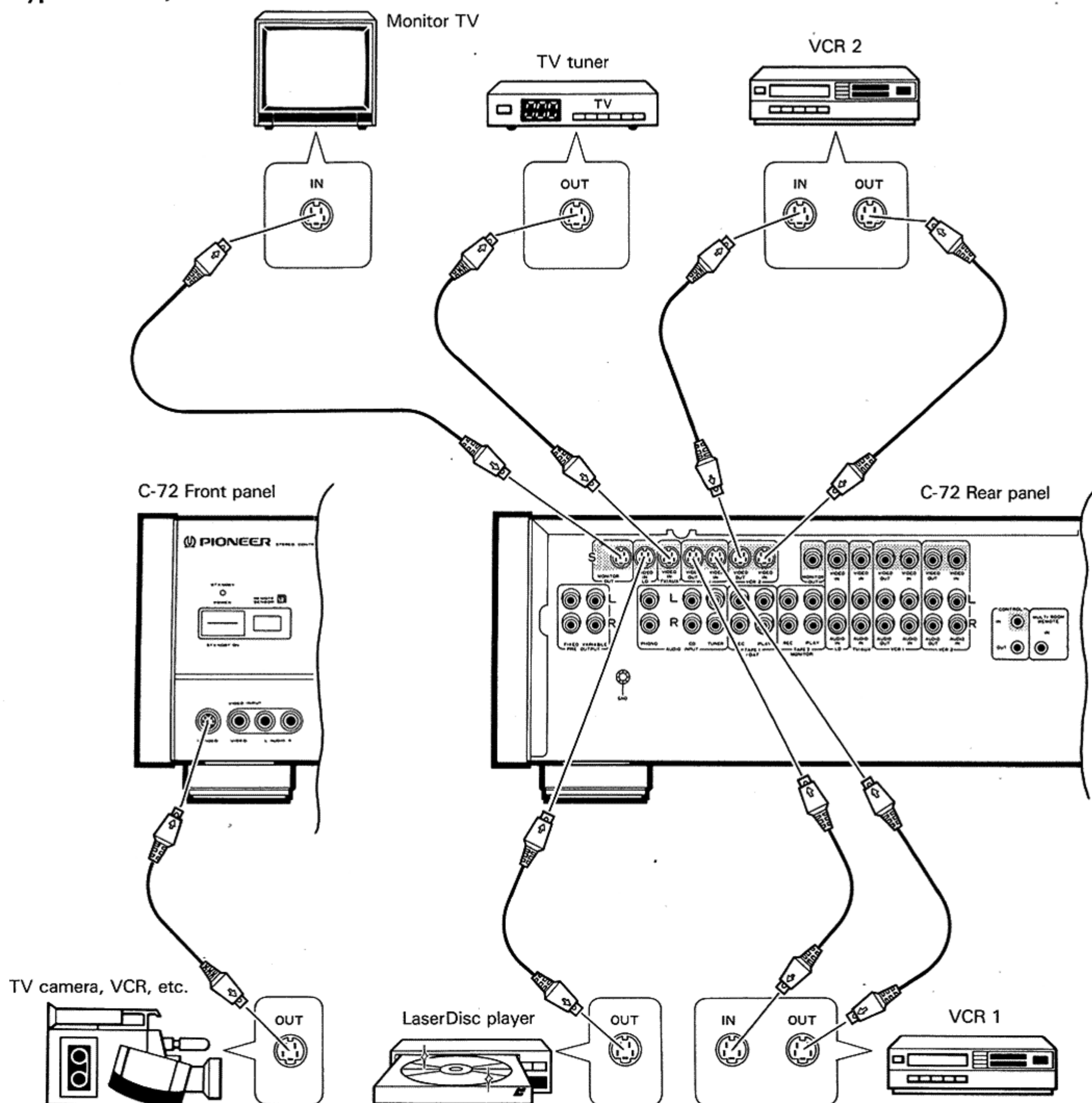

S type terminal provides only video signals, which necessitates the connection of audio cords L and R.

NOTE:

- Some VCRs, when connected to the S type terminal and video pin cord simultaneously puts priority on the S type terminal so that other signals cannot be recorded. For further information, see the operating instructions of the VCR you have purchased.
- To record an video from a video deck with S type terminal to that without S type terminal, connect the VIDEO OUT terminal on the video deck with S type terminal to the VIDEO IN terminal on this system using an video pin cord.
- Converting the S type terminal input to the composite output or the composite terminal input to the S type terminal output is impossible.
- When connecting this unit to another system using a S type terminal cord and video pin cord, approach both cords to each other as closely as possible.

■ Connecting Audio Input/Output Cords

- Use the red/white pin-plug cords.
- Connect the white plug to the L (left) channel and the red plug to the R (right channel). Be sure to insert the plugs into the terminals fully.

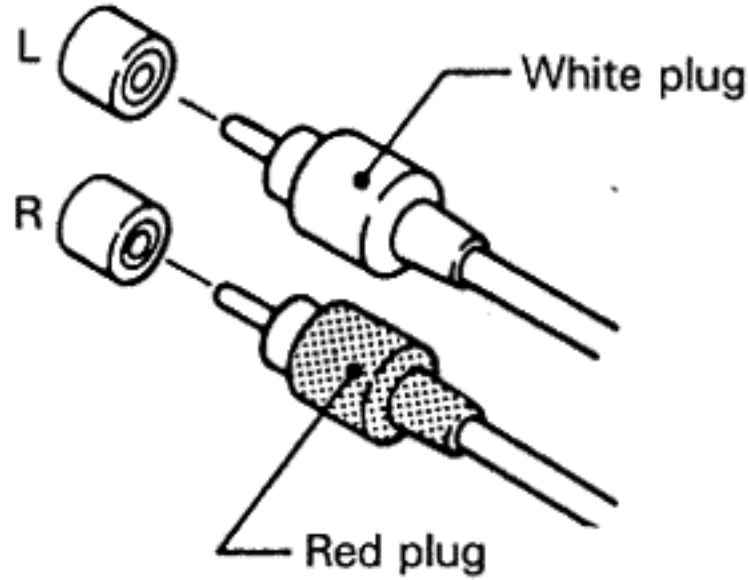

NOTE:

- Short pin plugs (16 in all) are fitted to each of the AUDIO IN terminals for PHONO, TUNER, TAPE 1/DAT PLAY, TAPE 2 MONITOR PLAY, LD, TV/AUX, VCR 1 and VCR 2 to improve sound quality. Remove these when making connections.
- Keep short pin plugs in a safe place. Do not insert in the REC, AUDIO OUT or VIDEO IN, OUT terminals.
- Replace short pin plugs in the terminals from which have they were removed when the terminal becomes vacant.

The short pin plugs may be inserted into these terminals only. Do not use the plugs for other terminals, as this may lead to no sound output or malfunction of the unit.

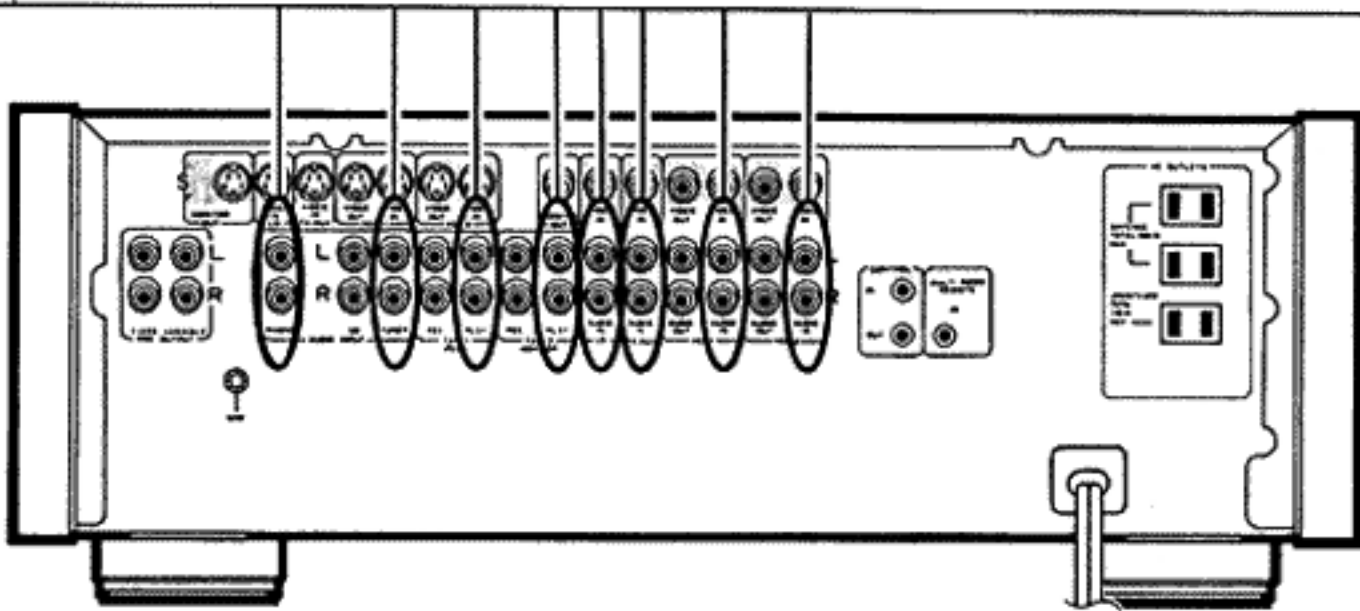

NOTE:

When there is no external unit to be connected to the terminals with short pin plugs, do not remove the short pin plugs.

■ Connecting Video Input/Output Cords

- Use pin-plug cords.
- Be sure to insert the plugs into the terminals fully.

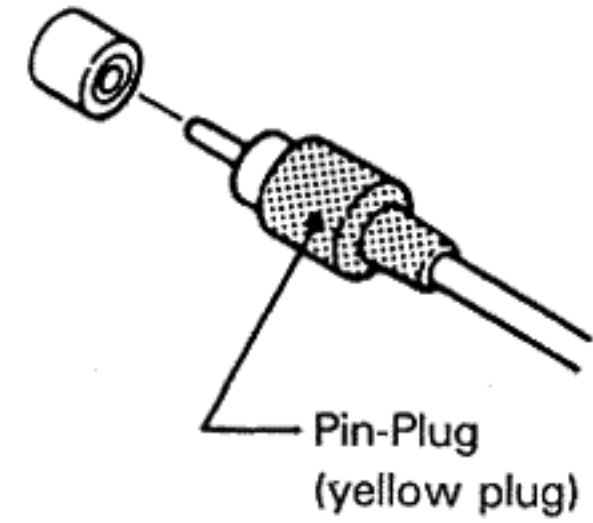

**CONNECTING THE POWER CORD
(For U.S. and Canadian models)**

Household electrical outlets are provided with specific polarity, a live side and a neutral (ground) side. This unit utilizes such polarity in order to improve sound quality. As shown in the illustration, be sure to insert the power plug so that its blades match the width of slots in the outlet.

Household electrical outlet.

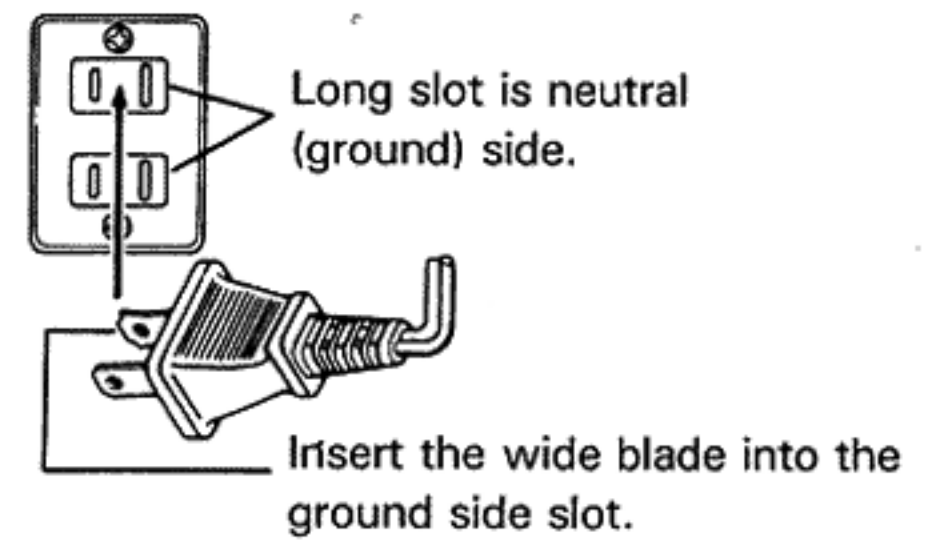

OPTIONAL MULTI-ROOM CONTROL ADAPTOR CONNECTION

NOTE:

Be careful not to make the wrong connections for CONTROL IN/OUT (black) and MULTI-ROOM REMOTE IN (green).

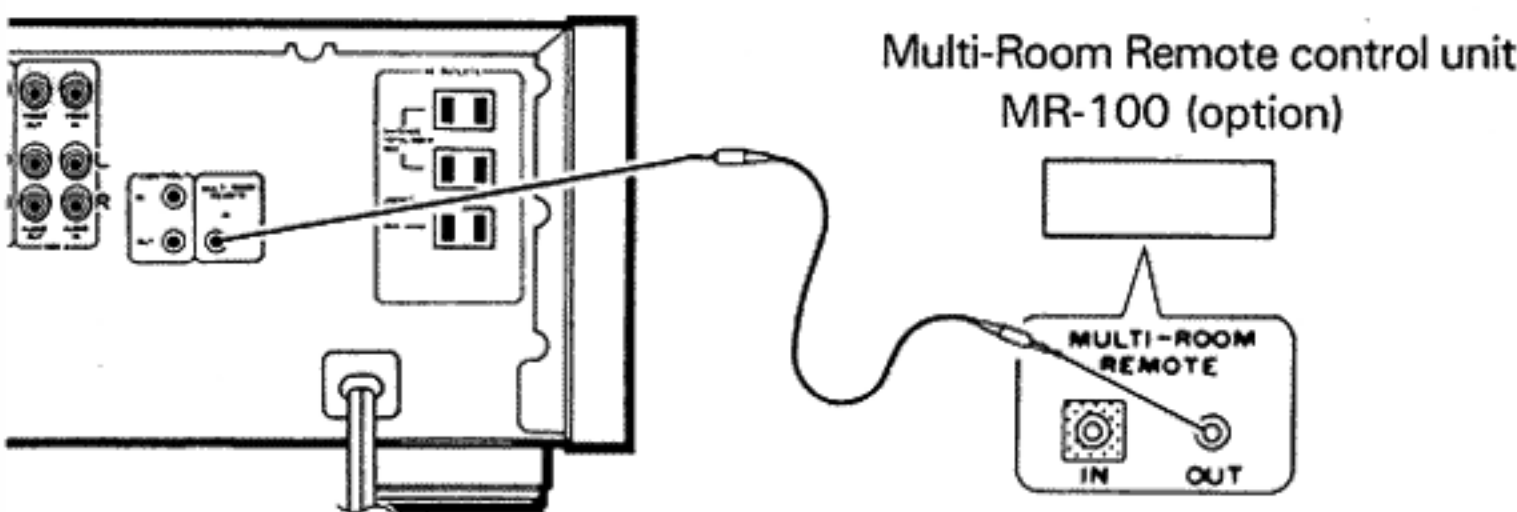

You can operate the main system by remote control from a different room in which are installed a speaker system or monitor TV set if you also install a Multi-Room remote control unit in that room.

- For details, see operating instructions for multi-room remote control unit MR-100.

[Set-up example]

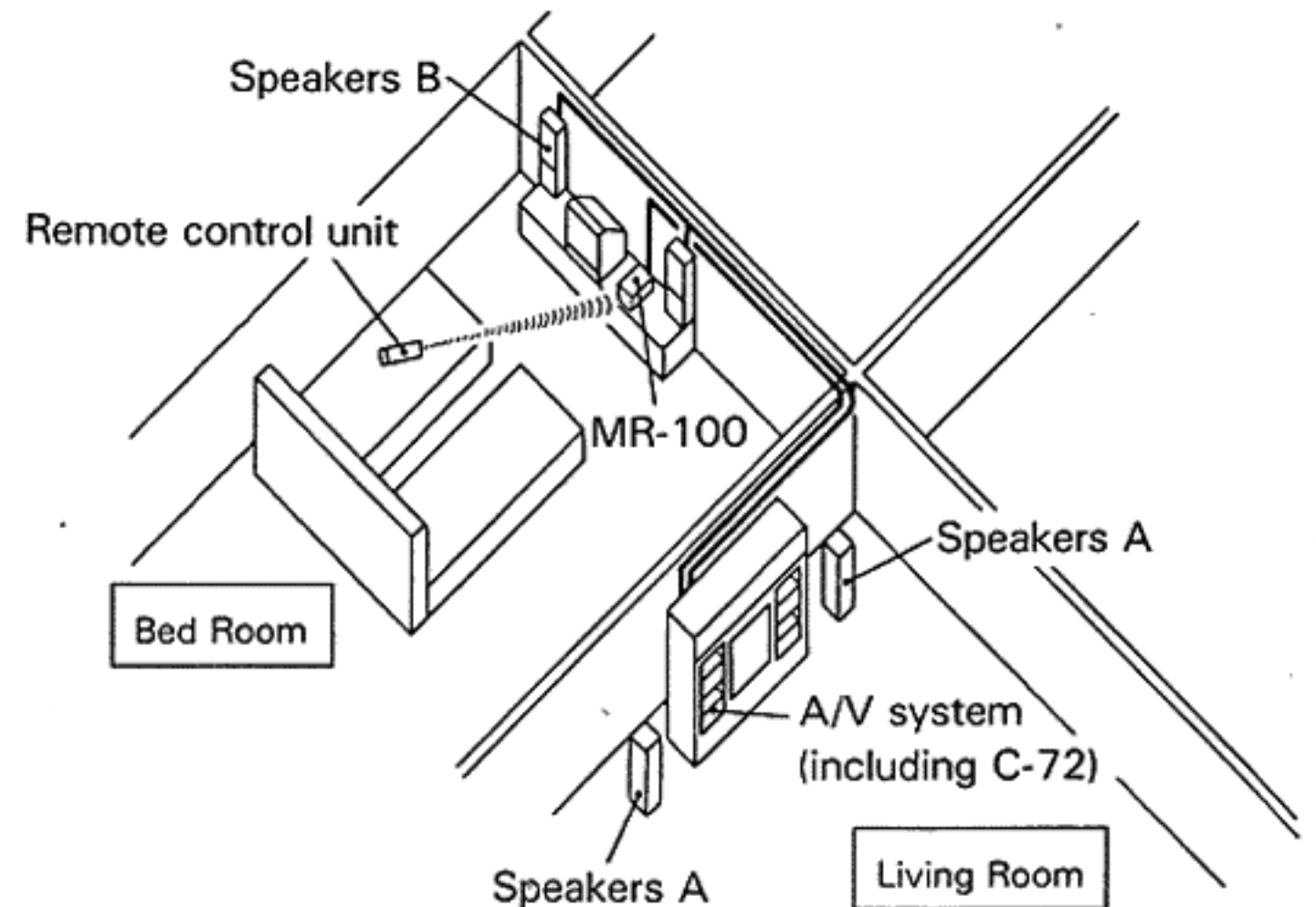

HOW TO USE THE PROGRAMMABLE (LEARNING) REMOTE CONTROL UNIT

LOADING BATTERIES

1. Open the battery compartment cover on the rear of the remote control unit. The cover should open easily if you slide it in the direction of the arrow while pressing on it with your thumb.
2. Take out the four supplied batteries (LR03/AM-4), and insert them into the battery compartment in accordance with the indications in the compartment.
3. Close the cover of the battery compartment.
4. Press the RESET button with the tip of a ball-point pen, etc.

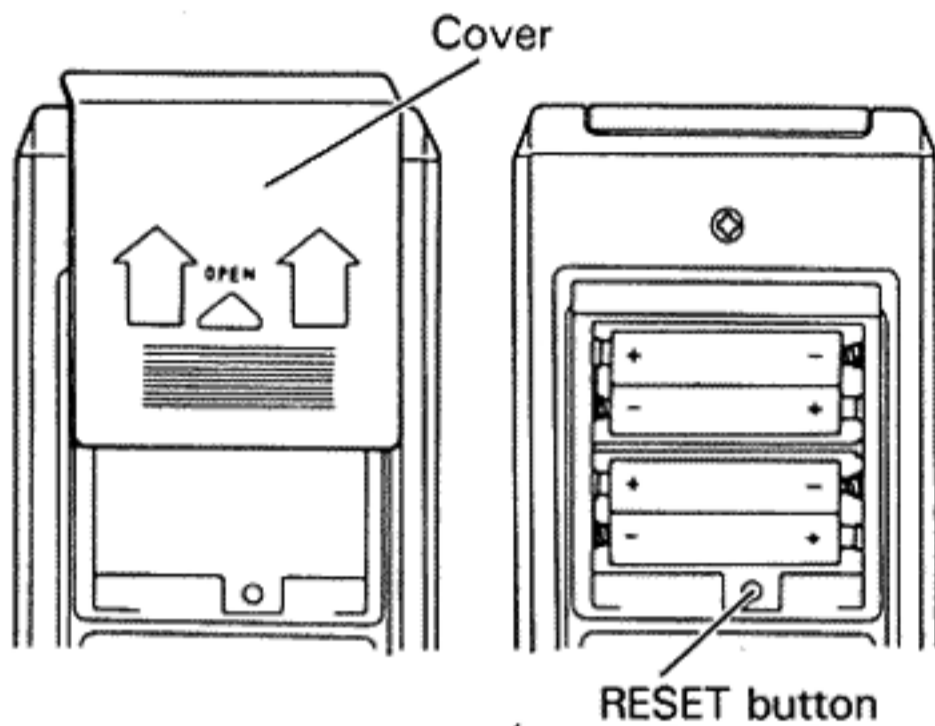

Incorrect use of batteries may lead to leakage or rupture. Always be sure to follow these guidelines:

- A.** Always insert batteries into the battery compartment correctly matching the positive + and negative - polarities, as indicated inside the compartment.
- B.** Never mix new and used batteries.
- C.** Batteries of the same size may have different voltages, depending on their type. Do not mix different types of batteries.

REMOTE CONTROL RANGE

When operating the remote control unit, point the front of the unit at the front panel of the control amplifier. The remote control unit may be used within a range of about 7 meters from the remote sensor, within angles of up to about 30 degrees.

Performance of the remote control unit is adversely affected in the presence of strong fluorescent light. Keep such lights away, especially from the sensor window.

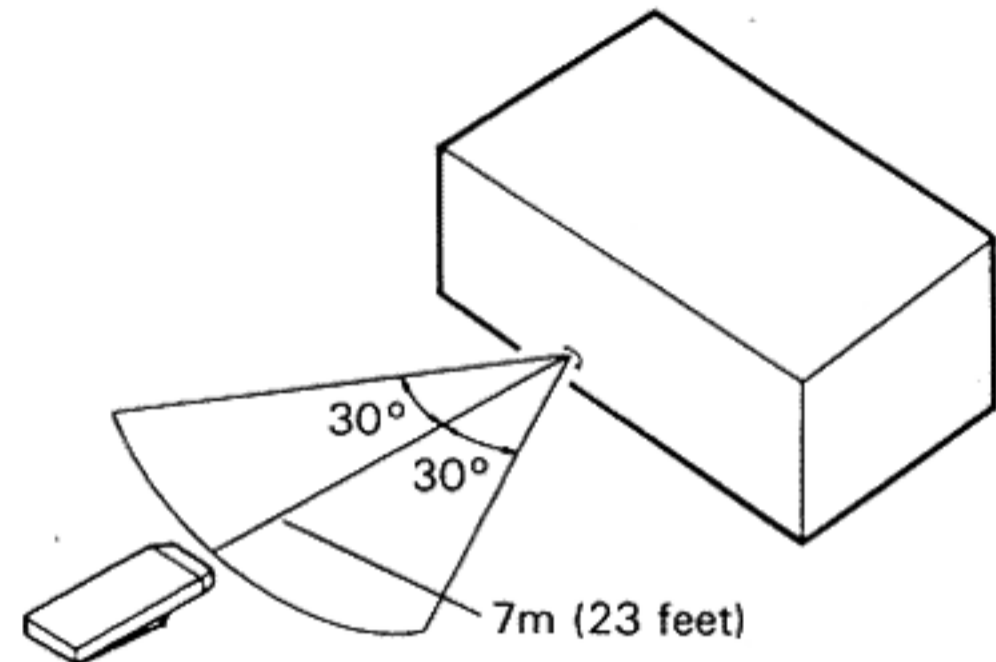

Battery Replacement

When the batteries have run out, the transmit indicator will not illuminate even when a key is pressed. Be sure to replace the batteries as soon as possible. As the programmed functions will be retained in memory only as long as batteries are inserted, remove the old batteries only if they can be replaced by new ones immediately.

Also, be sure to always use the specified batteries. (size "AAA" (LR03/AM-4) alkaline batteries)

NOTE:

When no batteries are inserted, the programmed memory contents will be erased after 30 to 60 minutes.

OPERATION

① TRANSMIT mode selector switch

AUDIO:

Select this position for remote control operation of audio equipment such as a CD player, cassette deck, turntable, tuner or amplifier.

VIDEO:

Select this position for remote control operation of video equipment such as a LaserDisc player, VCR or TV.

AUX:

Operation of some Sound Field Processor functions is possible.

The AUX mode is provided for programming extra commands in case you have filled up all the buttons in the VIDEO and AUDIO modes. If you do not program any new commands, then only the amplifier buttons will operate in this mode. You may wish to use this mode to assign extra commands for a second VCR, cassette deck etc.

- Buttons 1 to 12 are used as station buttons for TUNER and TV. (In the CD and LD modes 1 to 10 are number buttons, 11 is the MEMORY, and 12 is the CLEAR button.)
- The function buttons can be used in all modes.

② TRANSMIT indicator

This light flashes when remote control signals are being sent.

③ LEARN selector switch

For Pioneer components set this switch to SR RECALL.

Set to LEARN when programming the memory, and set to USE when using the memory (more about LEARN selector switch on page 16.)

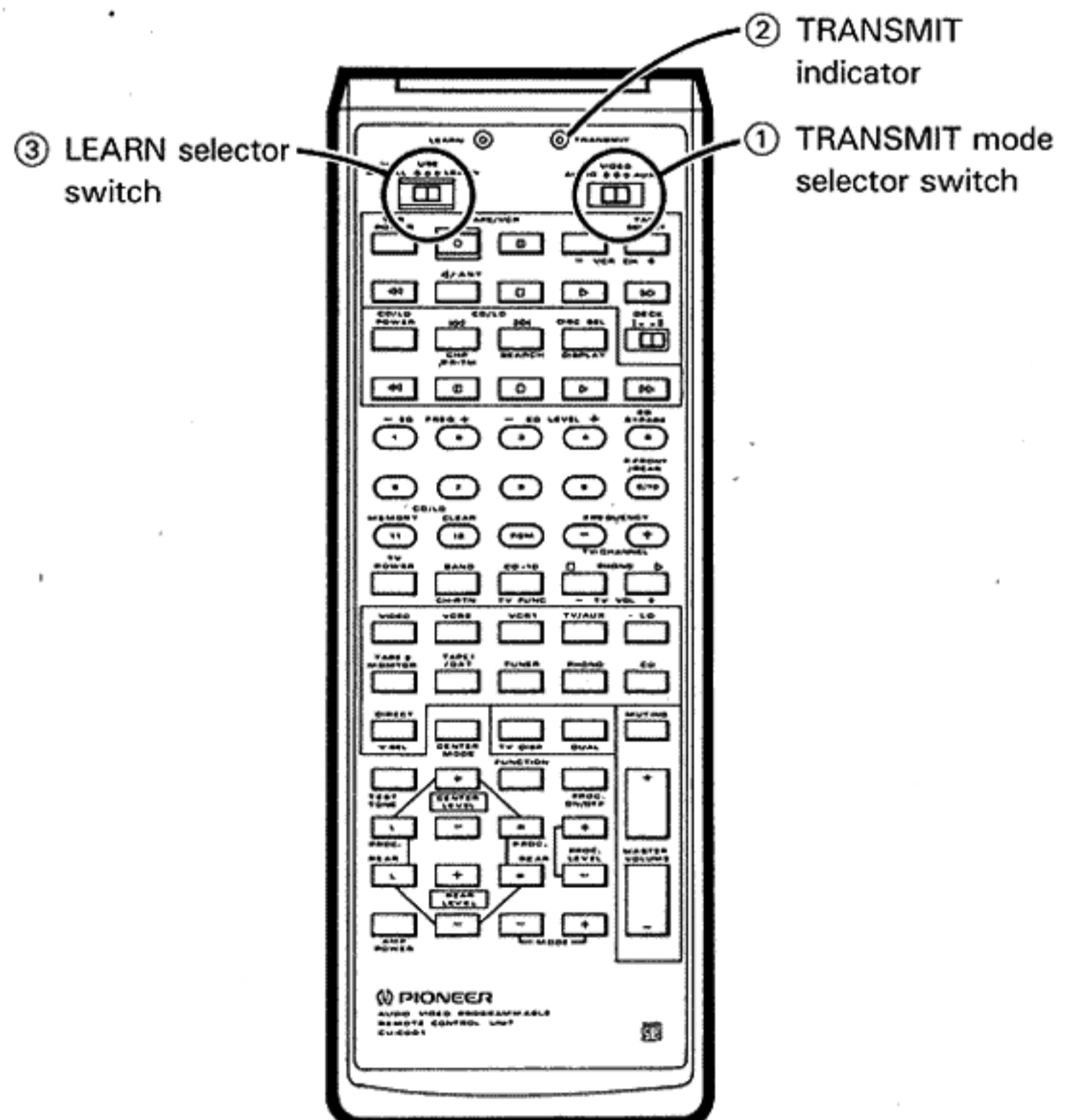

HOW TO USE THE PROGRAMMABLE (LEARNING) REMOTE CONTROL UNIT

The initial functions can operate all products compatible with PIONEER's common system remote control units marked with the symbol .

AMPLIFIER SECTION OPERATIONS

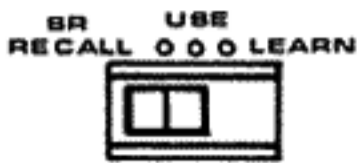

Set the LEARN selector switch to SR RECALL.

Unless otherwise specified, when the TRANSMIT mode selector switch is in the AUDIO, VIDEO, or AUX position, all come under the same command.

Input selector buttons:

Press LD, TV/AUX, VCR 1, VCR 2, VIDEO, CD, PHONO, TUNER or TAPE 1/DAT to select the amplifier input.

TAPE 2 MONITOR:

Press TAPE 2 MONITOR to switch between source and monitor.

DIRECT/V. SEL:

When using it as a DIRECT button (TRANSMIT mode selector: AUDIO):

Use it to switch the DIRECT mode ON and OFF.

When using it as a V. SEL button (TRANSMIT mode selector: VIDEO):

Use to switch the video component's video signal regardless of the position of the input selector.

AMP POWER:

Switches the amplifier power between ON and STANDBY.

MUTING:

(TRANSMIT mode selector: AUDIO & VIDEO)

This operates as an amplifier muting button.

(TRANSMIT mode selector: AUX)

This operates as a sound field processor muting button.

MASTER VOLUME (+, -):

(TRANSMIT mode selector: AUDIO & VIDEO)

Lets you adjust amplifier volume level.

(TRANSMIT mode selector: AUX)

Lets you adjust sound field processor volume level.

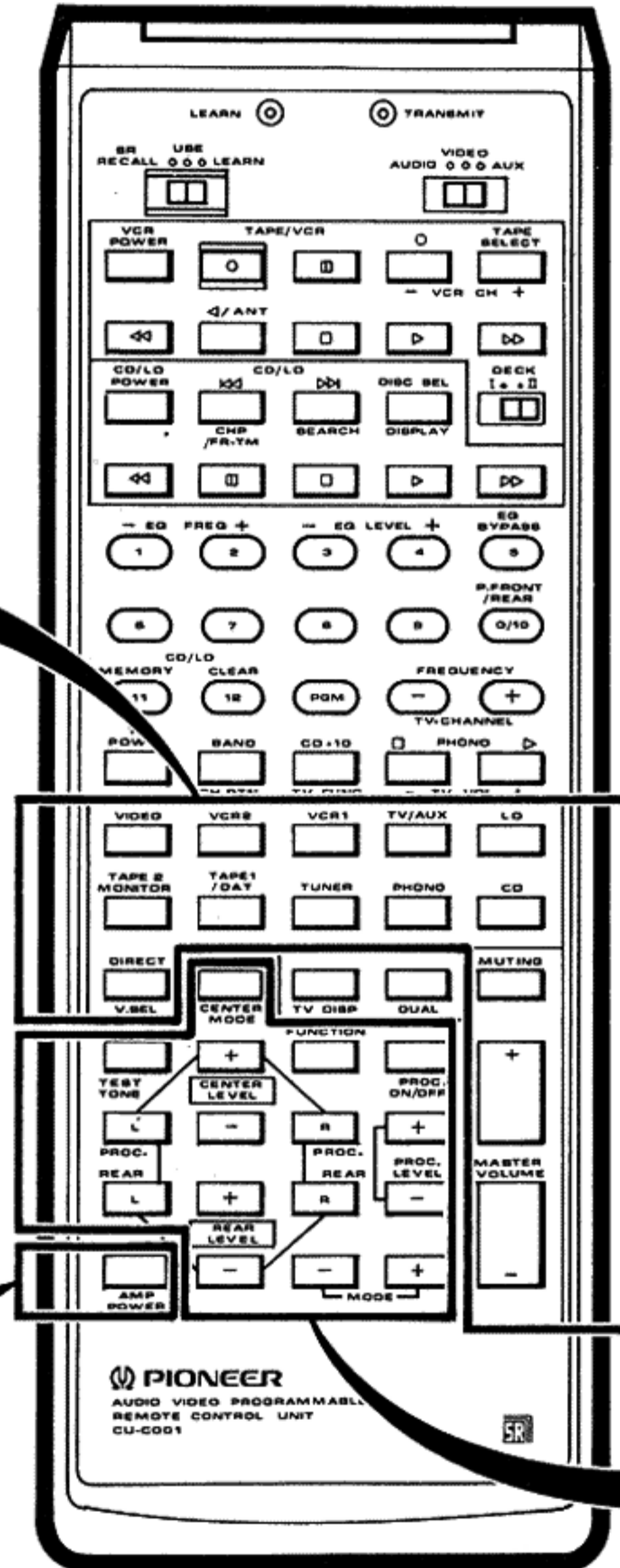

SURROUND & SOUND FIELD PROCESSOR (SP-91D or SP-700D) OPERATION

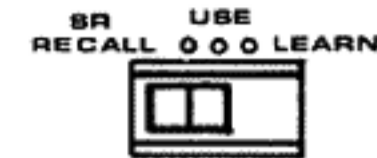

Set the LEARN selector switch to SR RECALL.

Unless otherwise specified, when the TRANSMIT mode selector switch is in the AUDIO, VIDEO, or AUX position, all come under the same command.

CENTER MODE:

Use this to change the CENTER MODE (NORMAL, WIDE, PHANTOM) in sequence when using DOLBY PRO LOGIC SURROUND and DOLBY 3 CH LOGIC.

TEST TONE:

- The test tone only operates when the function is SOUND FIELD CONTROL, or when DOLBY PRO LOGIC SURROUND has been selected in the surround mode.
- The test tone operates when the PROCESSING ON/OFF button on the remote control unit is ON.

For more details, refer to the SP-91D or SP-700D's operating instructions.

Level buttons:

Use when balancing volume levels.

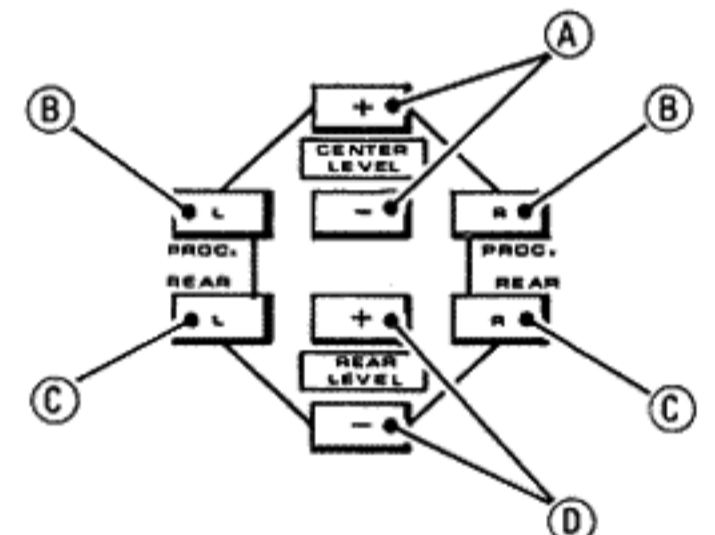

(A) CENTER LEVEL (+, -)

Adjusts the center speaker sound level.

(B) PROC. balance (L, R)

Adjusts the balance of the left and right processing front speakers.

(C) REAR balance (L, R)

Adjusts the balance of the left and right rear speakers.

(D) REAR LEVEL (+, -)

Adjusts the sound level of the rear speakers to the level of the front speakers.

PROC. (PROCESSING) ON/OFF:

When this is off, the reflected sound, equalizer, and other effects are cut, and only the original sound is reproduced.

PROC. (PROCESSING) LEVEL:

Increase (+) or decrease (-) the level of effect sound.

FUNCTION:

Selects functions such as Surround, Sound Field Control, Digital Equalizer, and User Programs.

MODE:

Use to select the program when using Sound Field, Surround, or a User Program. The + and - buttons switch programs in opposite directions.

Equalizer control buttons:



Set the
TRANSMIT
mode selector
switch to AUX.

EQ FREQ. (EQUALIZER FREQUENCY):

Select the frequency band to be equalized.

EQ (EQUALIZER) LEVEL:

Change the level of the selected frequency bands.

EQ (EQUALIZER) BYPASS:

Switches the equalizer ON and OFF.

P. FRONT (PROCESSING FRONT)/REAR:

Switches between processing front and rear.

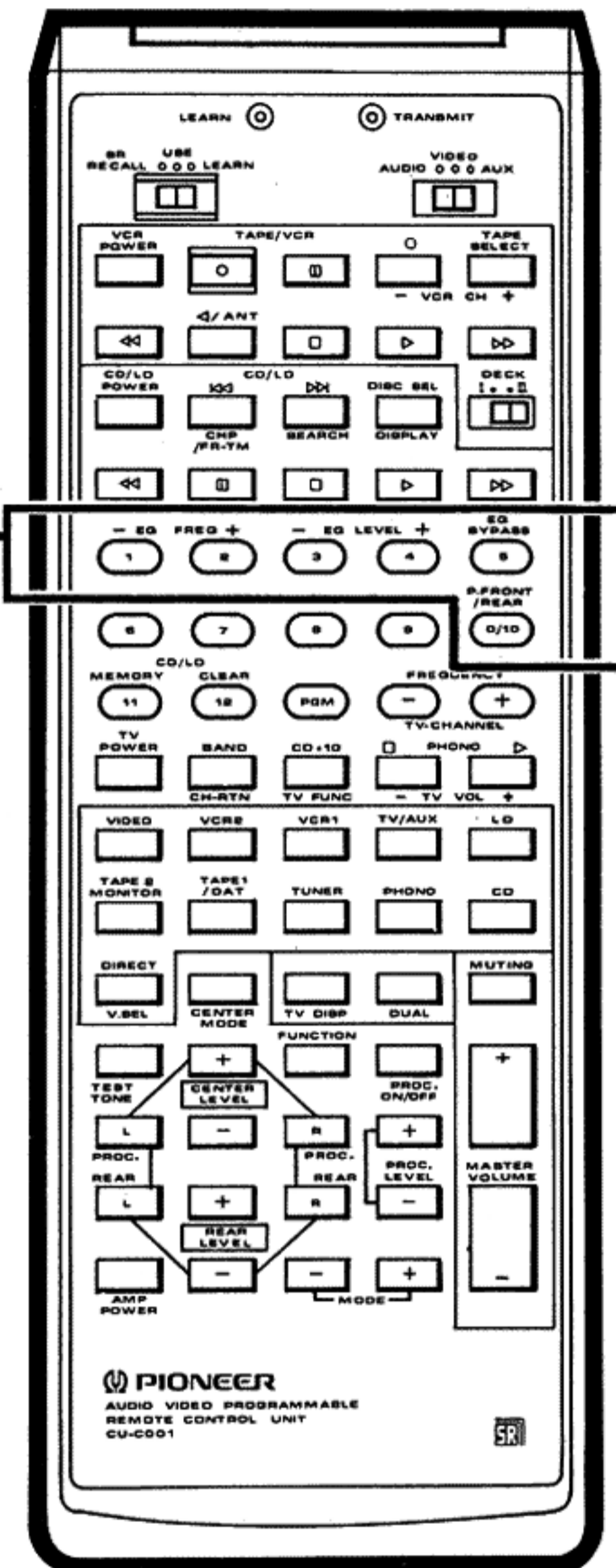

■ TUNER AND TURNTABLE OPERATIONS

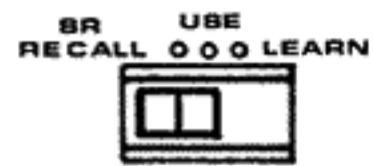

Set the LEARN selector switch to SR RECALL.



Set the TRANSMIT mode selector switch to AUDIO.

TUNER function buttons (operation of FM/AM Tuner)

1 to 12 (STATION CALL):

For recall of tuner presets.

FREQUENCY + (UP):

Shifts the frequency up.

FREQUENCY - (DOWN):

Shifts the frequency down.

BAND:

Switches the FM and AM bands in turn.

PHONO function buttons (operation of turntable)

▶ **(PLAY):**
Selects play.

■ **(STOP):**
Stops play.

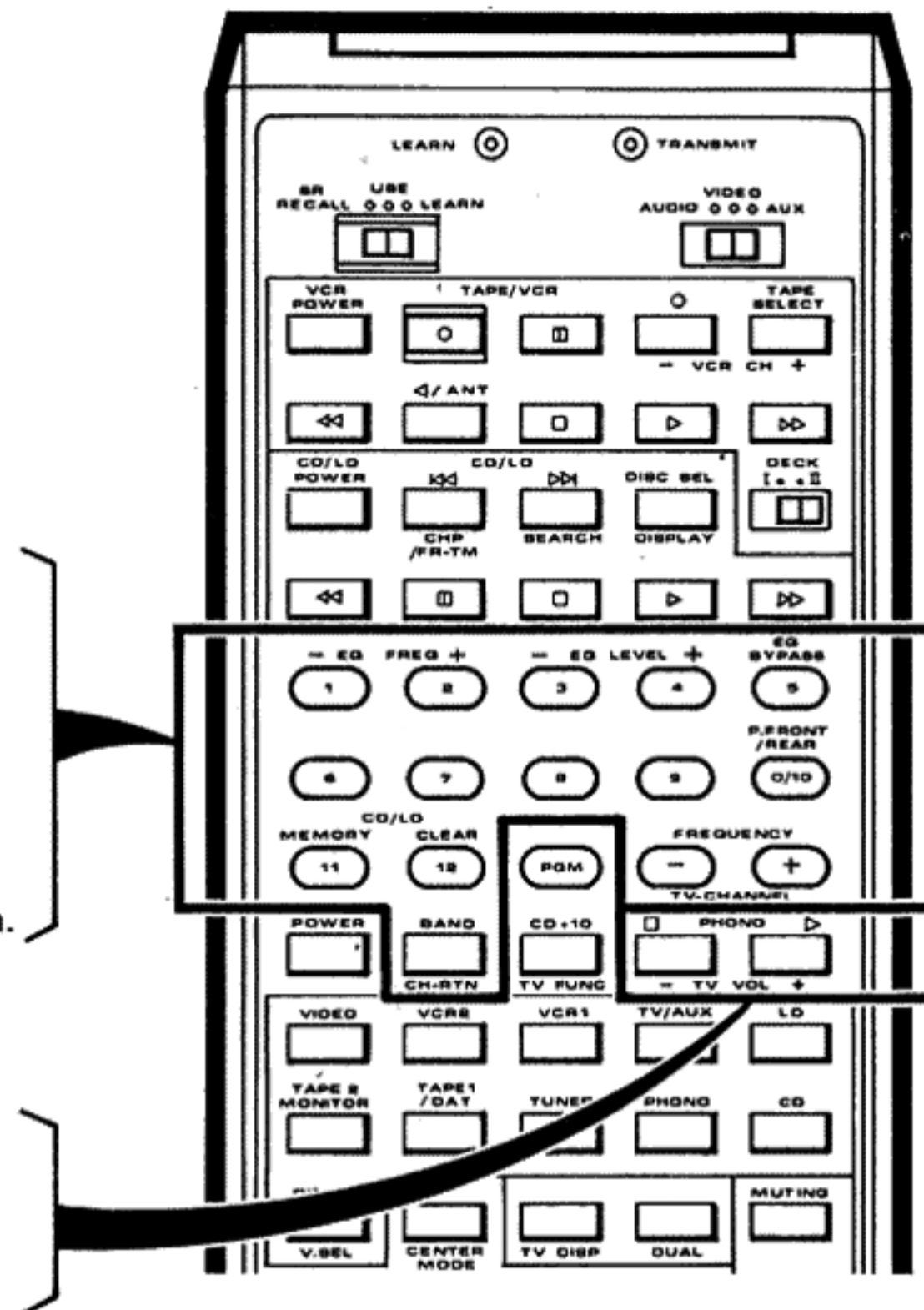

■ TV OPERATIONS

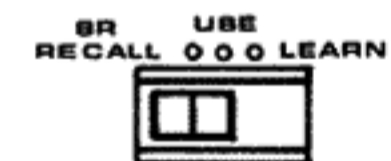

Set the LEARN selector switch to SR RECALL.



Set the TRANSMIT mode selector switch to VIDEO.

TV function buttons (operation of component display or projection monitor receiver)

1 to 12 (CHANNEL CALL DIGIT):
Used to call up channels.

CH-RTN (RETURN):
Returns to the previously received channel.

TV CHANNEL + (UP):
Changes the channel in the direction of larger CHANNEL CALL DIGIT numbers.

TV CHANNEL - (DOWN):
Changes the channel in the direction of smaller CHANNEL CALL DIGIT numbers.

TV VOL +, -:
Raises and lowers the volume.

TV POWER:
Switches the power of the TV ON/OFF.

TV FUNC (FUNCTION):
Used to change the TV FUNCTION.

TV DISP (DISPLAY):
TV image display ON/OFF.

• The TV FUNC button cannot be used with some Pioneer TVs.

DUAL:
Switches between MAIN, SAP, and MAIN + SAP during bilingual broadcast reception.

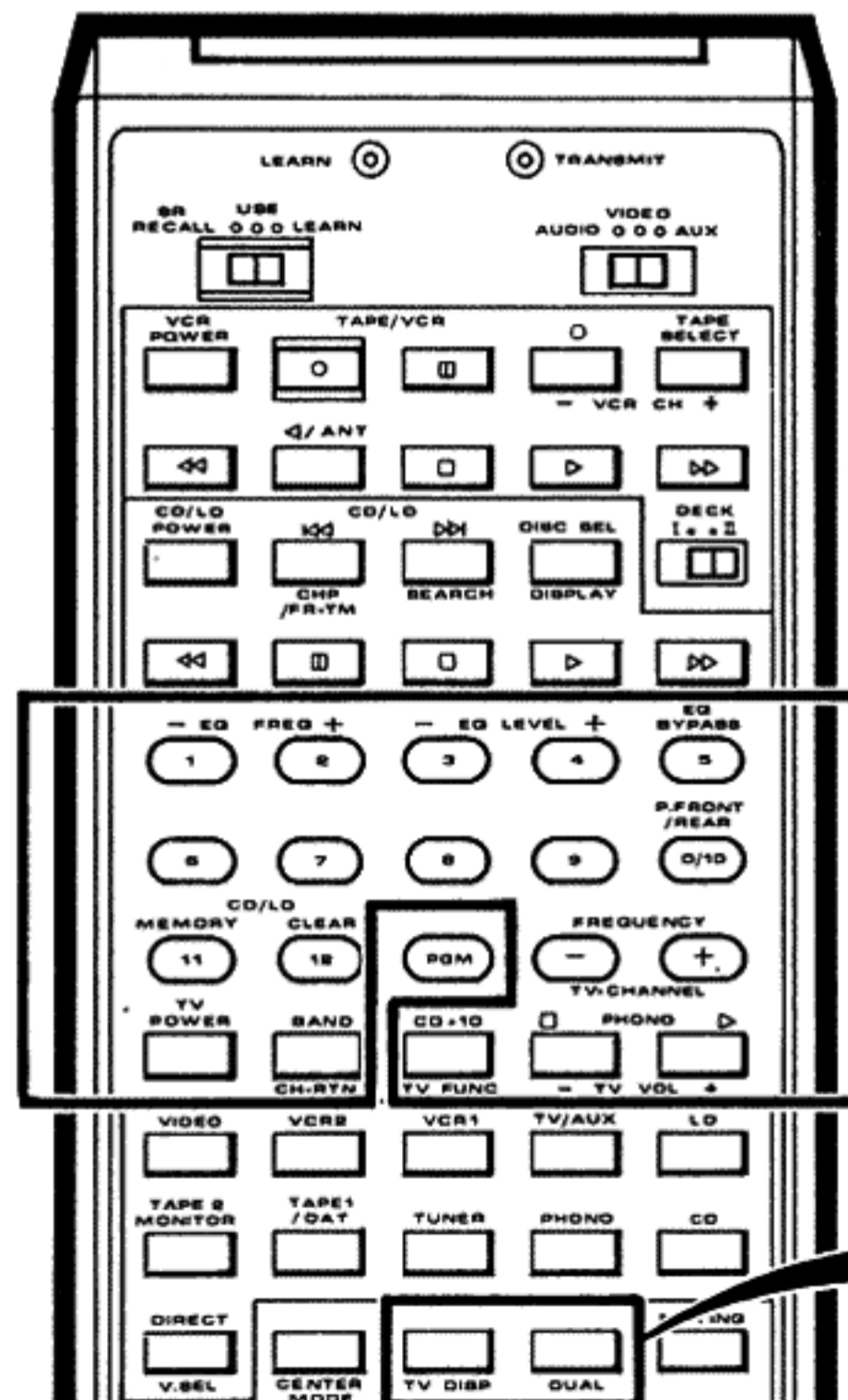

REMOTE CONTROLLING OF ANY OTHER OF YOUR AUDIO-VISUAL COMPONENTS VIA THIS UNIT REQUIRES:

1. All components must be remote controllable (have a sensor window on the front panel) to receive direct command from this unit, upon successful learning of those commands by this programmable unit or,
2. All units must have remote control jacks (IN/OUT) on the rear panel and be correctly connected to the amplifier according to the diagram on page 24.

CD PLAYER OPERATIONS

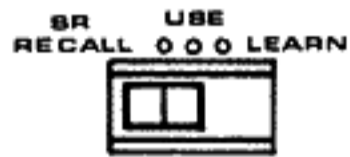

Set the LEARN select switch to SR RECALL.



Set the TRANSMIT mode selector switch to AUDIO.

CD Function buttons (Operation of CD player)

CD/LD POWER:

Switches CD player power ON/OFF. This only applies to CD player which you can switch ON/OFF by remote control.

◀ (TRACK SEARCH):

Returns to the beginning of the track currently in playing.

▶▶ (TRACK SEARCH):

Advances to the next track.

DISC SEL:

Selects the DISC No. (1 to 6) for Multi-play CD players.

PGM (PROGRAM):

Press to program the CD player.

◀ (MANUAL SEARCH):

Selects fast backward.

|| (PAUSE):

Pauses playback.

■ (STOP):

Stops playback.

▶ (PLAY):

Selects playback.

▶▶ (MANUAL SEARCH):

Selects fast forward.

1* - 0/10* (numeric):

For direct selection of a track or programming of tracks.

MEMORY*:

Memorizes a program.

CLEAR*:

Erases a memorized program.

* When using as CD buttons, first press the PGM button. If you don't press the PGM button, these buttons will operate as buttons for the STATION CALL tuning function.

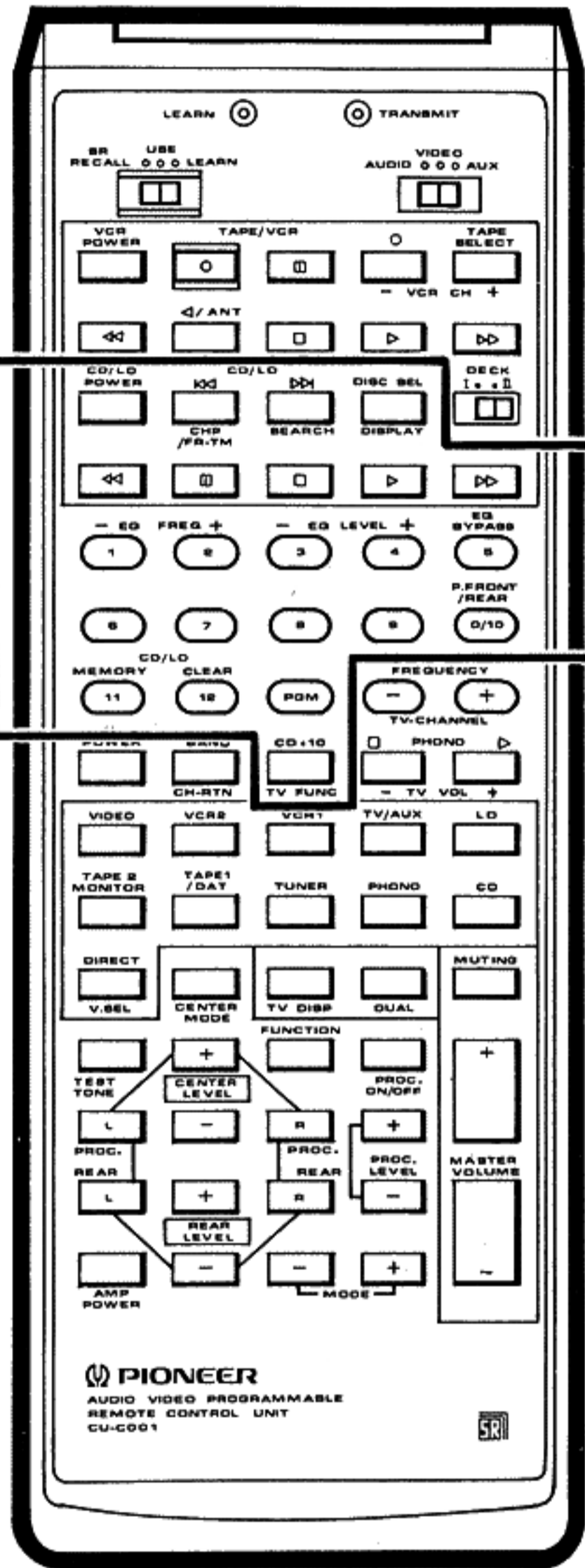

CD + 10:

Use this button when programming a TRACK NUMBER higher than 10. (Example) When programming TRACK NUMBER 21, press the CD + 10 button twice and then button 1.

NOTE:

You may not be able to use the CD + 10 button with certain CD players.

LD OPERATIONS

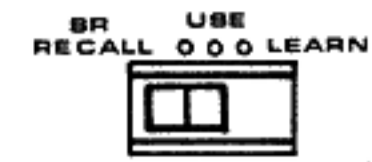

Set the LEARN select switch to SR RECALL.



Set the TRANSMIT mode selector switch to VIDEO.

LD function buttons (operation of LD player)

CD/LD POWER:

Switches LD power ON/OFF. This only applies to LD players which you can switch ON/OFF by remote control operation.

DISPLAY:

Clears the chapter and frame/time displays on the screen.

PGM (PROGRAM):

Allows use of chapter program play, frame search and time search.

◀ (SCAN):

Selects fast backward.

|| (PAUSE):

Video and audio are stopped and playback is paused.

■ (STOP/EJECT):

Playback is stopped when pressed once. Pressing again causes the disc tray to come out.

▶ (PLAY):

Selects playback.

▶▶ (SCAN):

Selects fast forward.

1* - 0/10* (numeric):

Used for chapter and frame/time number search and for chapter program play.

MEMORY*:

Used for chapter program play.

CLEAR*:

Used for releasing repeat playback, number correction and mode release during search operation, and for releasing chapter program play.

* When using as LD buttons, first press the PGM button. If you don't press the PGM button, these buttons will operate as buttons for the TV CHANNEL CALL tuning function.

CHP/FR-TM

(CHAPTER/FRAME•TIME):

Used for chapter or frame (time) search operation.

SEARCH:

Used for the search operation and for the memory repeat operation.

■ CASSETTE DECK OPERATIONS

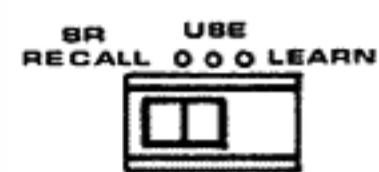

Set the LEARN select switch to SR RECALL.



Set the TRANSMIT mode selector switch to AUDIO.

TAPE function buttons (operation of cassette tape deck and multi-cassette changer)

- (REC MUTE): For insertion of silent spaces between selections.
- (REC): Selects the recording or recording standby mode.
- ▯ (PAUSE): Temporarily stops tape transport. Press again to resume tape transport.
- ◀ (FF): Rapidly advances the tape in the direction of the arrow.
- ◀ (PLAY): Selects reverse playback.
- (STOP): Stops the tape transport.
- ▶ (PLAY): Selects forward playback.
- ▶▶ (FF): Rapidly advances the tape in the direction of the arrow.

TAPE SELECT:
Selects the cassette No.(1 to 6) for multi-cassette changer.

DECK I/DECK II switch:
This switch selects the deck to be used.

NOTE:

- Some cassette decks cannot be controlled using these buttons.
- The ◀ button can only be used with cassette decks capable of reverse play.
- Some buttons will not work with some types of cassette decks. Refer to the operating instructions for more information.

■ VCR OPERATIONS

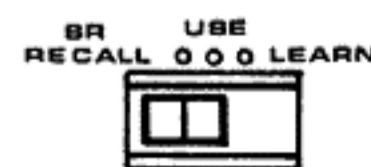

Set the LEARN select switch to SR RECALL.



Set the TRANSMIT mode selector switch to VIDEO.

VCR function buttons (operation of VCR)

- VCR POWER:**
Switches VCR power ON/OFF.
- (REC): Selects the recording mode.
- ▯ (PAUSE/STILL): Sets pause and still picture.
- VCR CH - (DOWN):**
Shifts channels in descending order.
- VCR CH + (UP):**
Shifts channels in ascending order.
- ◀ (REW): Rewinds the tape and allows picture search.
- ANT*:**
This button can be used only for VCRs with a VCR/TV selector. Toggles the antenna output between VCR and TV.
- (STOP): Stops tape transport.
- ▶ (PLAY): Selects playback.
- ▶▶ (FF): Rapidly advances the tape and allows picture search.

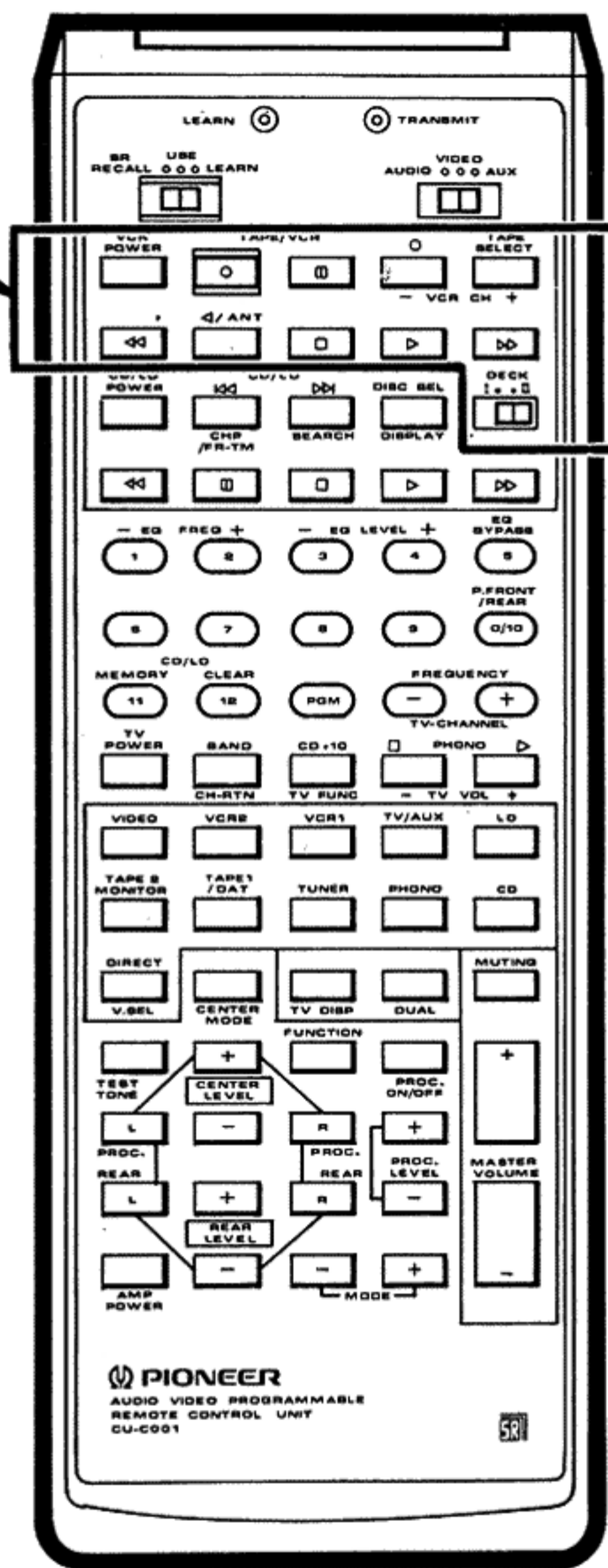

* For switching the antenna input for an optional VCR, the code of the VCR remote control must be memorized.

PROGRAMMING

Introduction

This system's remote control can "learn" the commands of other remote control units, regardless of manufacturer, as long as the other unit is of the infrared type.

On rare occasions, programming this unit may be impossible with some special types of infrared remote control units.

In some cases you may still need the original remote control unit for special situations. But as a rule, you will be able to use this Pioneer remote control for most system control needs, including video as well as audio equipment.

LEARNING BUTTONS

All the buttons are programmable. When programming a button, the previous program on the button is erased.

The Pioneer unified remote control code is already programmed in the unit. If your audio and video equipment consists of Pioneer components, the remote control unit can be used as is. If you wish to program functions which do not already exist in the memory, use the LEARN function to program them. It is also possible to return to the original Pioneer commands after programming other commands. (Refer to Page 17 "Returning to the Initial Settings" for this procedure.)

- In each mode, one function per button can be programmed.
- When presetting buttons, make sure that the remote control units of both this and the other components are loaded with fresh batteries.

LEARNING CAPACITY

A maximum of 226 commands can be learned (about 150 commands are adequate for Pioneer's remote control signal). More commands than this can't be programmed even if there are buttons which have not been preset.

AUDIO mode

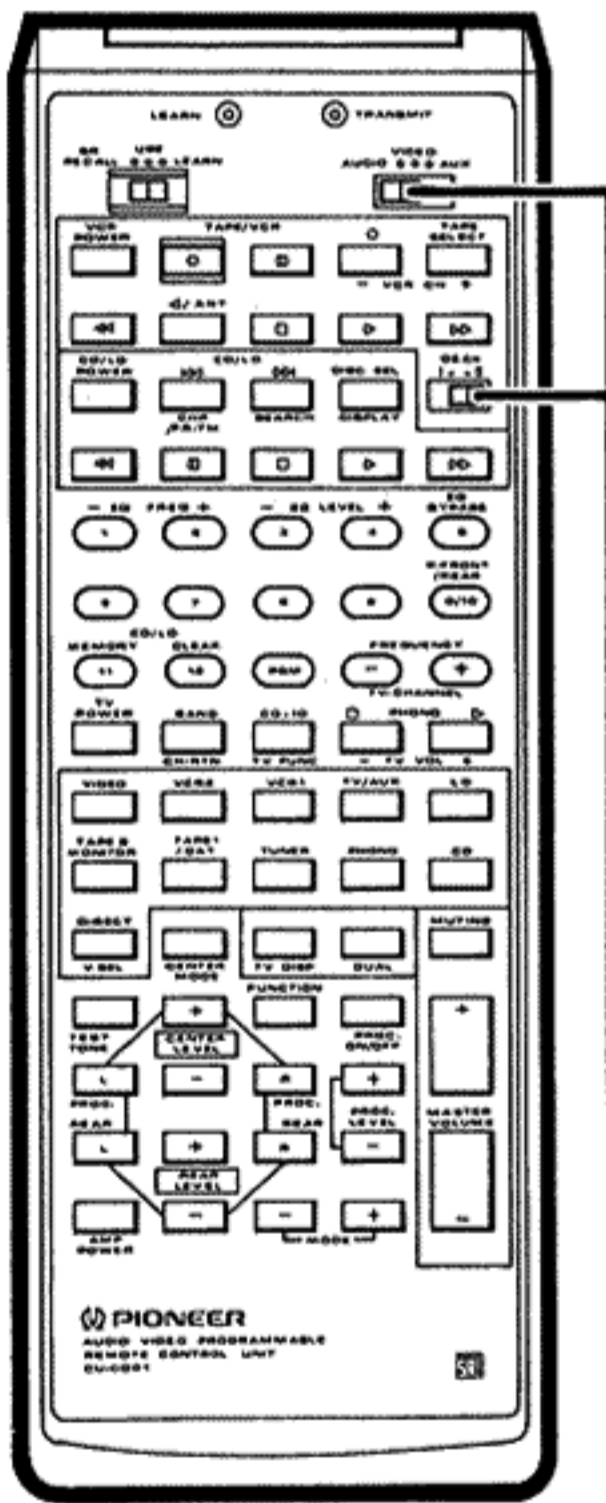

In the AUDIO MODE, the TAPE function buttons can be programmed to store commands for DECK I and DECK II depending on the position of the DECK I/DECK II switch. (A maximum of 82 buttons can be programmed.)

VIDEO mode

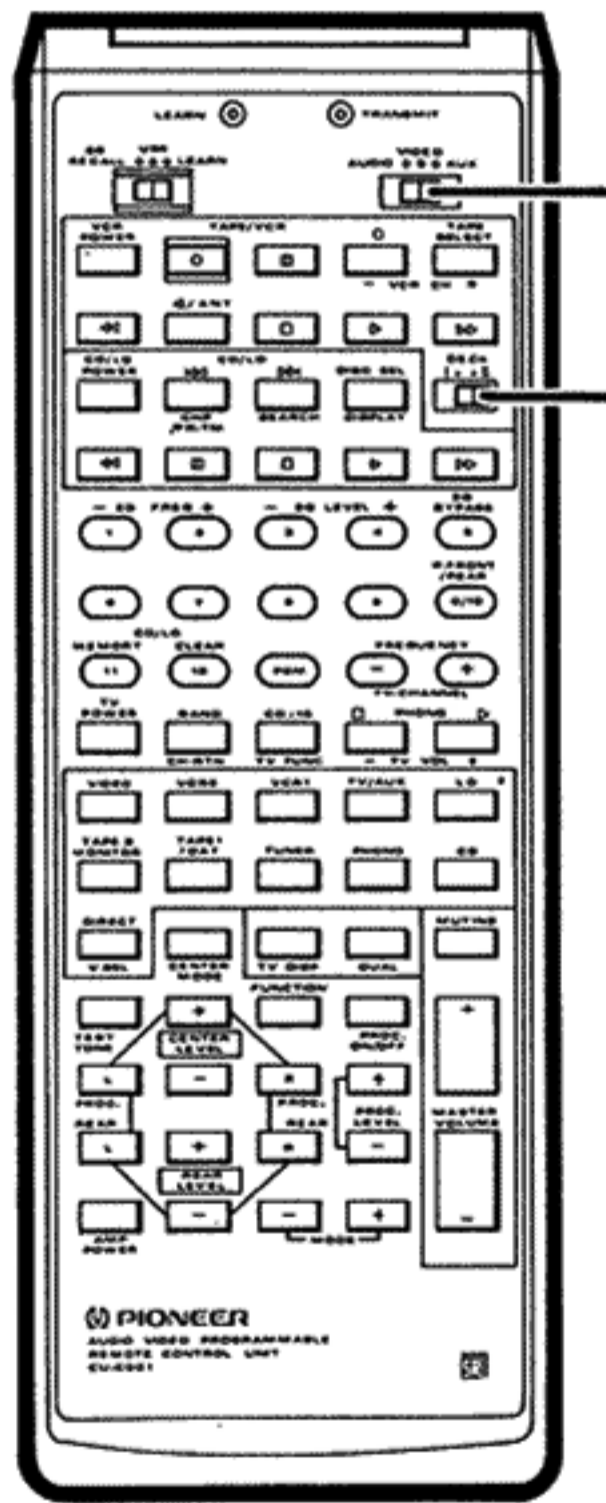

In the VIDEO mode the DECK I/DECK II switch is inoperative. (A maximum of 72 buttons can be programmed.)

AUX mode

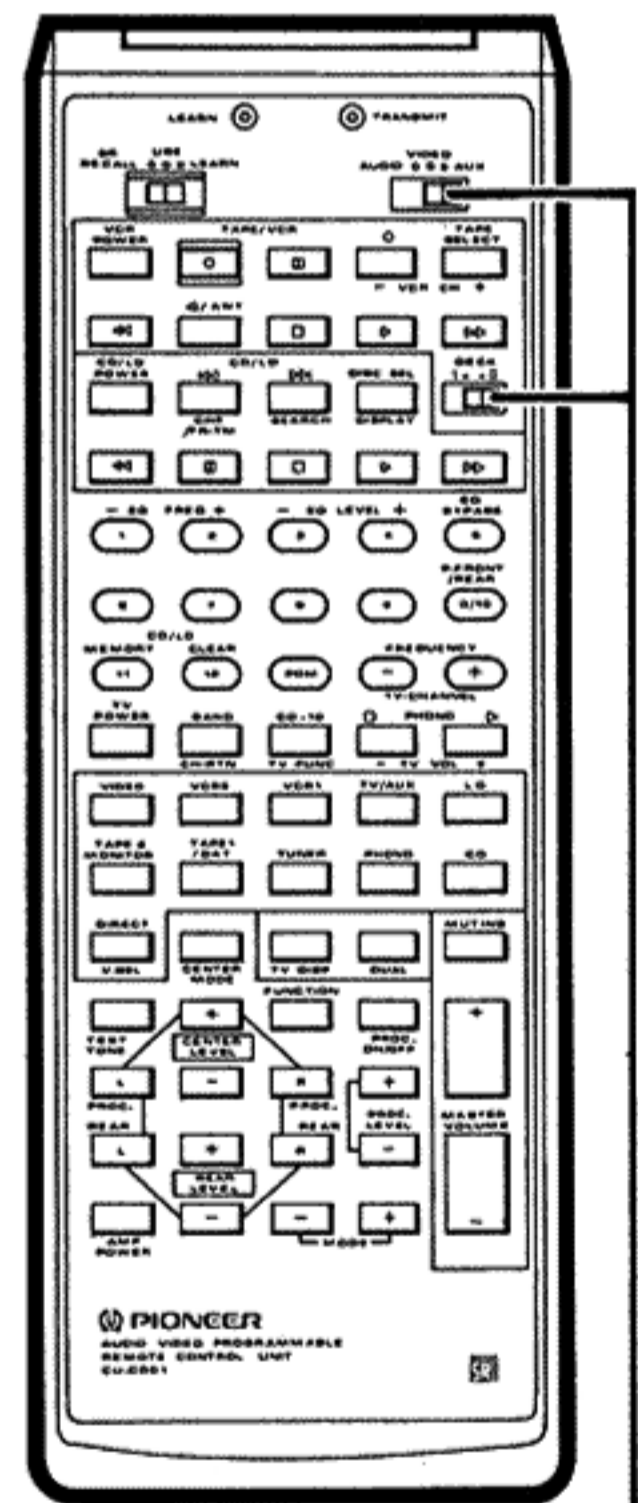

In the AUX mode the DECK I/DECK II switch is inoperative. (A maximum of 72 buttons can be programmed.)

When teaching functions with names that differ from those of the buttons, write in the names or codes of the functions on the supplied templates and place on the buttons.

HOW TO USE THE PROGRAMMABLE (LEARNING) REMOTE CONTROL UNIT

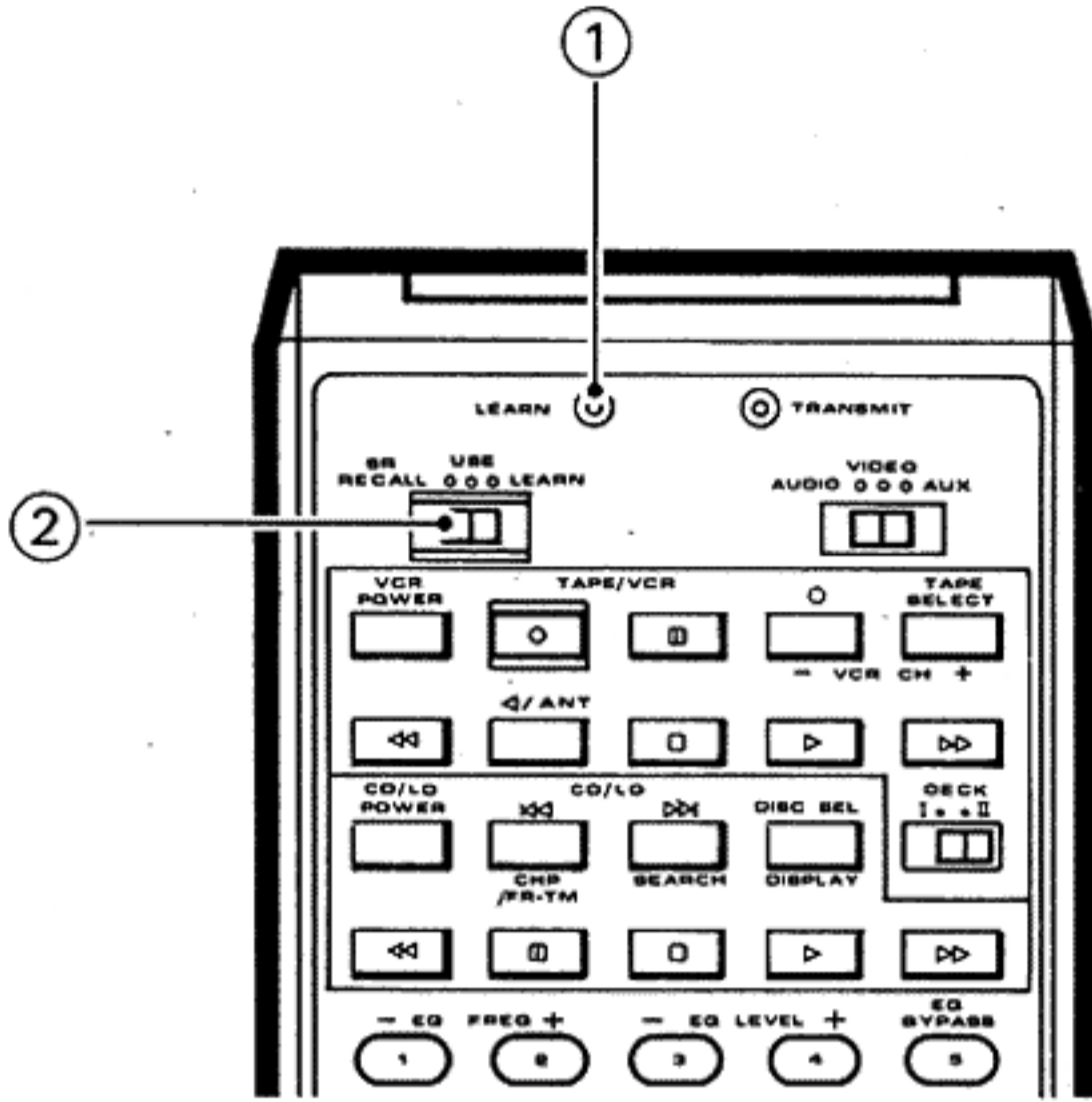

① LEARN indicator

This indicator lights when the Learn function is activated.
ON: Learning is possible.
OFF: Regular remote control functions can be performed.

NOTE:

If the LEARN indicator flashes, this indicates that the program capacity has been exceeded and that the last command is not memorized.

② LEARN selector switch

This can be set as follows:

LEARN:

This position is used for storing the codes of your remote control unit.

USE:

- Set to this position after codes have been stored in the LEARN position. (Set to this position when using memorized commands.)

SR RECALL:

Set to this position when transmitting Pioneer unified remote control code signals (Marked on the remote control unit).

[Operation example]

1. Set the LEARN switch of the programmable remote control unit to the LEARN position and set the TRANSMIT mode selector switch to the VIDEO position.
 - Programming is possible with the TRANSMIT mode selector switch in any position, but VIDEO is used as an example.
2. Place the transmission sections of the programmable remote control unit and the remote control of the VCR facing each other.

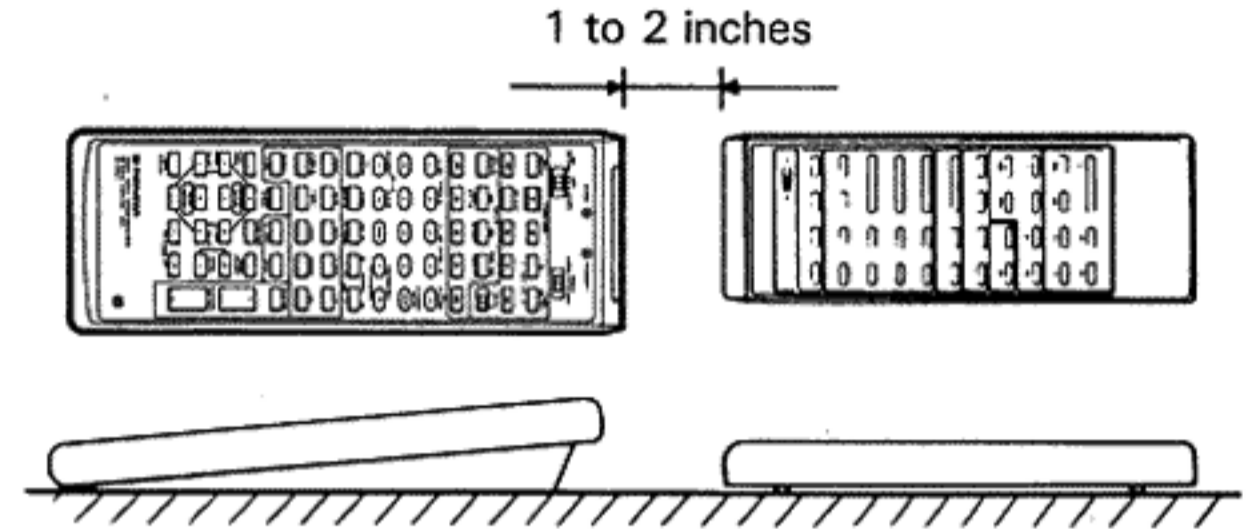

- Place the two units on a table, separated by 2 to 5 cm (1 to 2 inches).

Memorization will not be possible if they are too close.

3. Hold down the VCR PLAY button of the programmable remote control unit until the LEARN indicator lights up, then release the button.
4. Hold down the PLAY button of the VCR remote control unit.
5. Release the button of the VCR remote control unit after making sure that the LEARN indicator has gone out on the Pioneer remote control unit.

NOTE:

If the LEARN indicator flashes, it indicates that you are trying to preset a button not available for the learning function, or otherwise the program capacity has been exceeded, the function programmed last will not be memorized correctly. All previously programmed functions, however, will be retained in memory and may be used as they are if the last function is not essential. For re-programming refer to page 17 "Returning to the Initial Settings."

6. Set the LEARN selector switch of the programmable remote control unit to the USE position.
 - The previous code (Pioneer uniform remote control code or code for other equipment) is erased and replaced by the new code.
7. Check that the program works.
 - Try actual operation and make sure the unit works properly.
 - If the VCR does not operate when pressing the button, change angle, position and distance between the remote control units and repeat the programming procedure.
 - When programming, make sure that the function indications (for example, ►, ►►, ■) on the other remote control unit and the programmable remote control unit are the same. This will facilitate operation.

NOTE:

Be careful when using the learn function because signals from the transmitting remote control unit may be reflected from walls or the ceiling, and may arrive at the sensor of a component other than the programmable remote control unit. It's a good idea to remove the tape from a cassette deck or VCR in case they are accidentally activated. It is also preferable to unplug the power cords of system components from power outlets, or cover the remote sensors of remote controlled components to prevent accidental operation.

Questions and Answers about the Learning Function

- Q:** The remote control unit of my VCR has two REC (recording) buttons. They both have to be pressed at the same time to start recording. What is the learning procedure in this case?
- A:** Hold one of the buttons on the programmable remote control depressed (for example the VCR ● button) until the LEARN indicator lights up, and then press the two buttons on the VCR remote control simultaneously.
- Q:** The remote control unit of my VCR has a REC (recording) button and a PLAY (playback) button and they both have to be pressed at the same time to start recording. What is the learning procedure in this case?
- A:** Hold one of the buttons on the programmable remote control depressed (for example the VCR ● button) until the LEARN indicator lights up, and then press the REC and PLAY buttons on the VCR remote control simultaneously.
- As described above, operations which require two buttons to be pressed at the same time are programmed by pressing the two buttons simultaneously.

Operating other equipment using the programmable remote control unit

1. Set the LEARN switch of the programmable remote control unit to the USE position.
2. Set the TRANSMIT mode selector switch to the desired position (AUDIO/VIDEO/AUX).
 - Set to the VIDEO position for programming as described in the example.
3. Press the button of the desired function.
 - The TRANSMIT indicator lights up while the remote control unit is sending codes.

NOTE:

- When operating programmed buttons, always set the LEARN selector switch to the USE position. Operation is not possible in the LEARN position.
- For functions which require two buttons to be pressed at the same time (recording etc.) or functions for which several codes are sent simultaneously (auto functions, timer programming, etc.) the programming procedure is different and improper operation may occur.

Returning to the Initial Settings

1. Set the LEARN selector switch to the LEARN position.
2. Remove the battery cover.

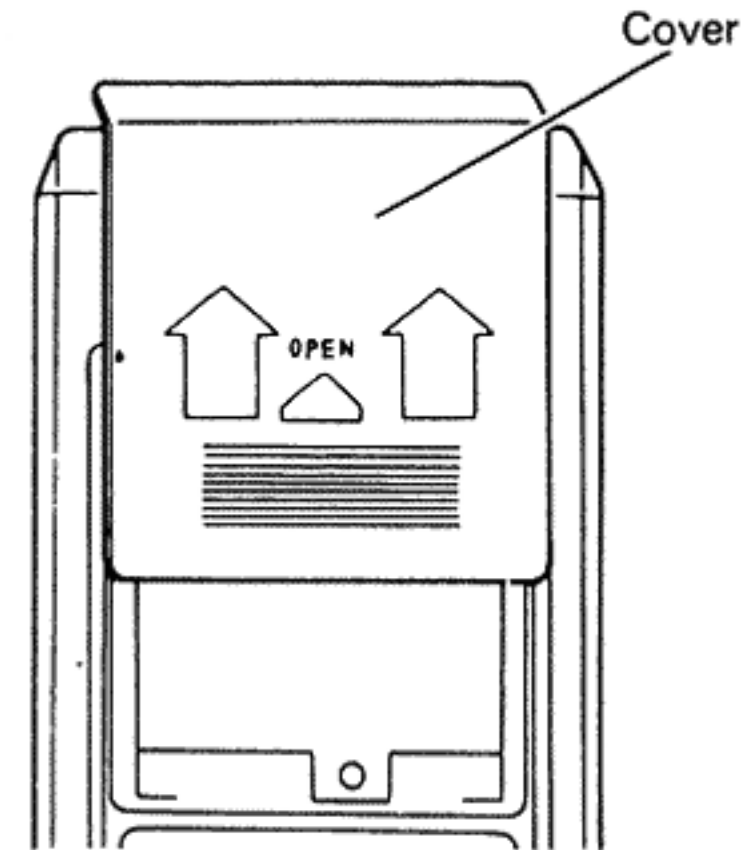

3. Press any of the buttons available for programming. The LEARN indicator will illuminate.
4. Use a ball-point pen or similar object to press the RESET button while the LEARN indicator is flashing.

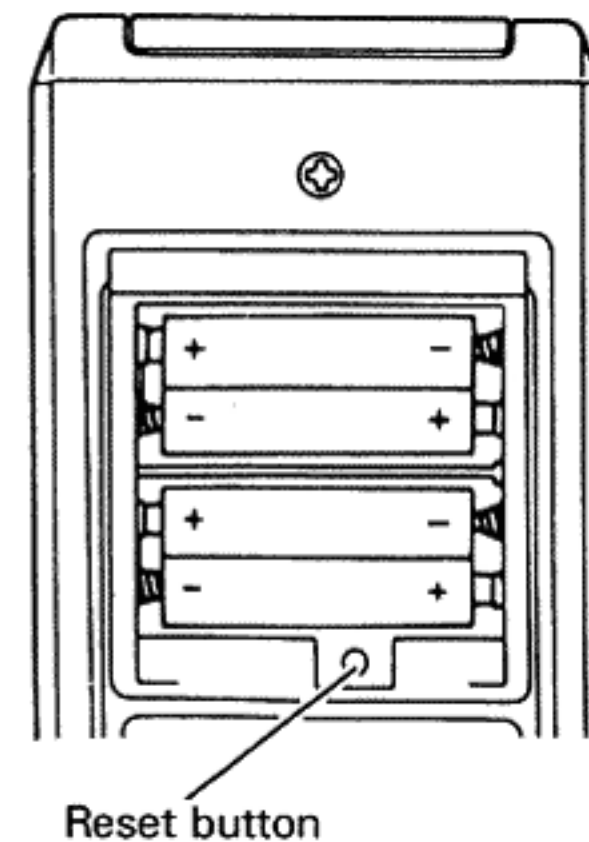

- The programmed functions for the AUDIO, VIDEO and AUX positions are cleared, and the remote control unit is reset to the Pioneer uniform remote control codes.
- Press the button gently; do not use excessive force.

PANEL FACILITIES

FRONT PANEL

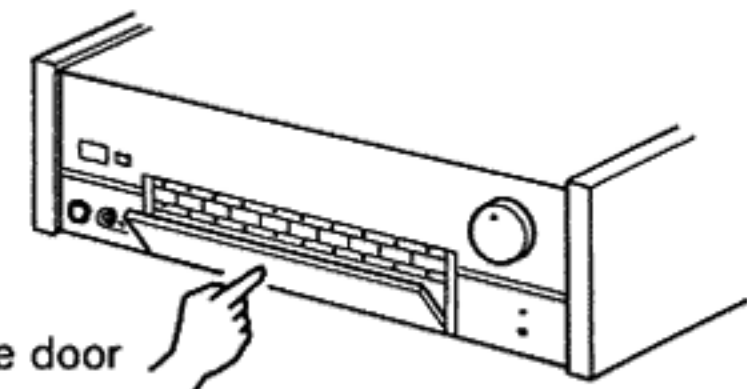
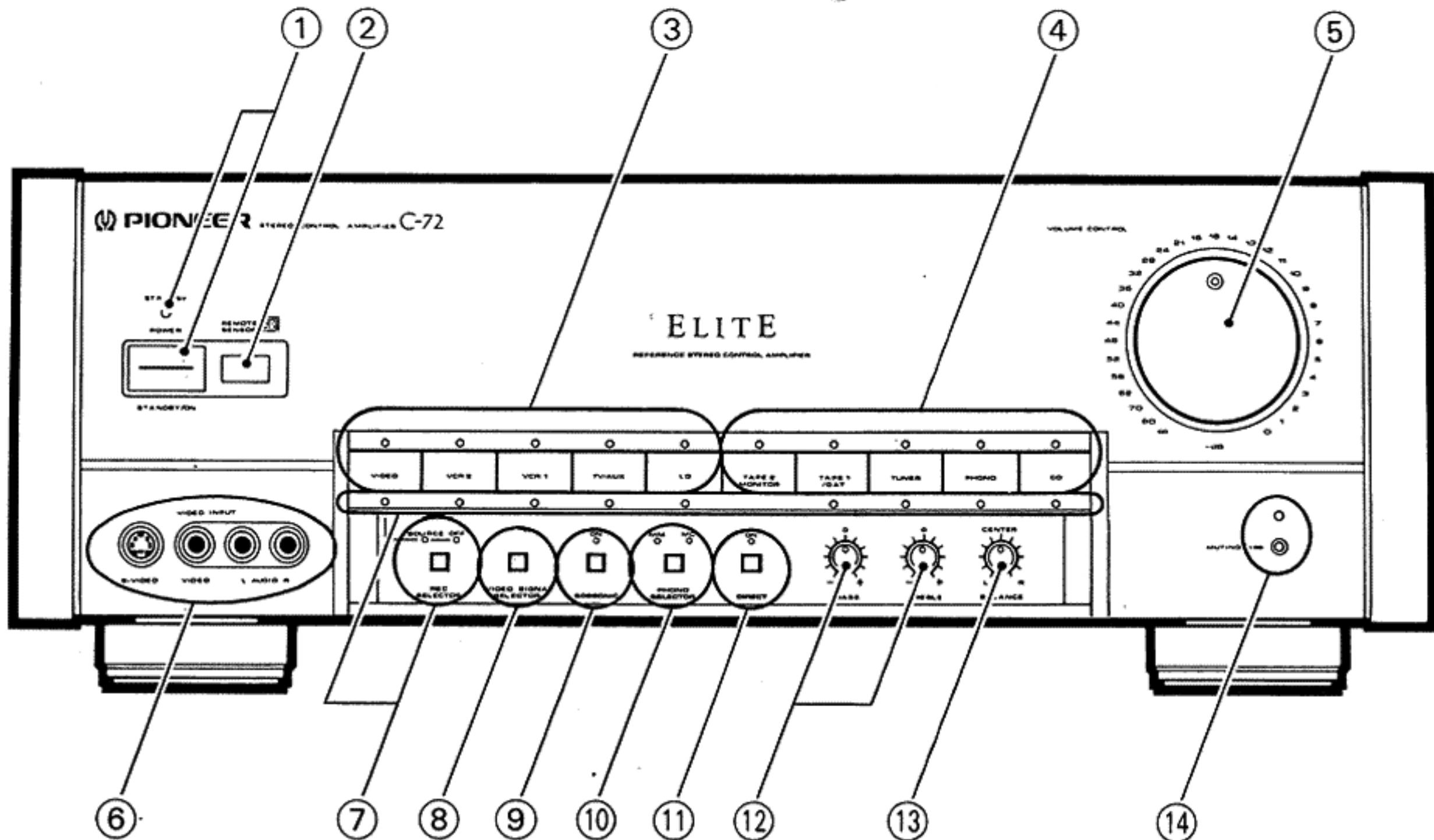

Press the top part of the door in the center to open.

① POWER STANDBY/ON switch/indicator

This is the switch for electric power.

ON: When set to the ON position, power is supplied and the unit becomes operational. The STANDBY indicator is off.

STANDBY: When set to the STANDBY position, the main power flow is cut and the unit is no longer fully operational. A minute flow of power feeds the unit to maintain operation readiness. At this time the STANDBY indicator is on.

② REMOTE SENSOR

③ VIDEO INPUT selector buttons/indicators

Use to select the video component for play back.

[VIDEO]: To play back the video equipment connected to the front panel VIDEO INPUT terminals.

[VCR 2]: To play back the VCR connected to the rear panel VCR 2 terminals.

[VCR 1]: To play back the VCR connected to the rear panel VCR 1 terminals.

[TV/AUX]: To use the TV tuner or a monitor TV connected to the rear panel TV/AUX terminals.

[LD]: To play back the video disc player connected to the rear panel LD terminals.

- The red indicator above the button lights to show the selected video source.
- When selecting with the VIDEO SIGNAL SELECTOR button ⑧, a yellow indicator above the button lights.
- The indicator under the button lights when selection is made with the REC SELECTOR button ⑦.

④ AUDIO INPUT selector buttons/indicators

Use to select the audio component for playback.

[TAPE 2 MONITOR]: To use the cassette deck connected to the rear panel TAPE 2 MONITOR terminals.

[TAPE 1/DAT]: To use the cassette deck connected to the rear panel TAPE 1/DAT terminals.

[TUNER]: For listening to FM/AM broadcasts with a tuner.

[PHONO]: For turntable.

[CD]: For compact disc player.

- The TAPE 2 MONITOR button go ON or OFF alternately each time they are pressed, independently of the other buttons.
- The red indicator above the button lights to show the selected audio source.
- The indicator under the button lights when selection is made with the REC SELECTOR button ⑦.

⑤ VOLUME CONTROL

Use to adjust the sound volume. At the [- ∞] position, sound will not be heard, while at the [0] position, sound volume will be at its maximum.

⑥ VIDEO INPUT terminals

Video components such as a video camera can be connected here.

AUDIO: Connect to the video component's audio output terminals.

VIDEO: Connect to the video component's video output terminal.

S-VIDEO: Connect to the video component's S-VIDEO OUT terminal.

⑦ REC SELECTOR button/indicators

Use to select the playback source component used when performing audio and video recording. The audio and video signals (in the case of an audio component) from the select component will be output from the OUTPUT terminals. When set to SOURCE (indicator lights), the signals selected with the audio or video input selector switch will be output.

Each time you press the REC SELECTOR button, the playback source changes in sequence in the following order.

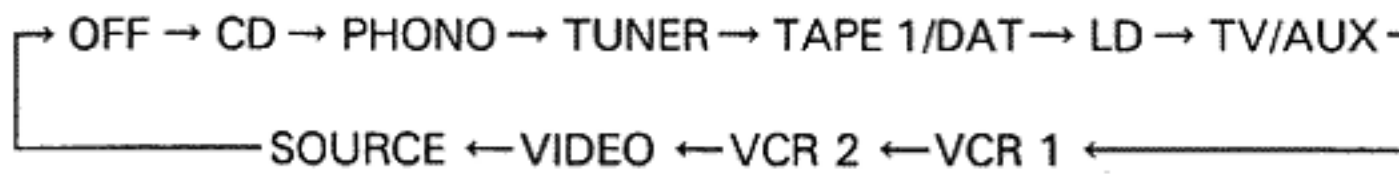

NOTE:
No signal is output to the OUT (or REC) terminal of the input component selected with the recording selector switch. For example, when REC SELECTOR is used to select VCR 1, no signal will be output to the OUT terminal of VCR 1.

⑧ VIDEO SIGNAL SELECTOR button

Use to switch the video component's video signal regardless of the position of the input selector switch. The yellow indicator above the video input selector buttons to show the video signal selected with these buttons.

Each time you press the VIDEO SIGNAL SELECTOR button, the video source changes in sequence in the following order.

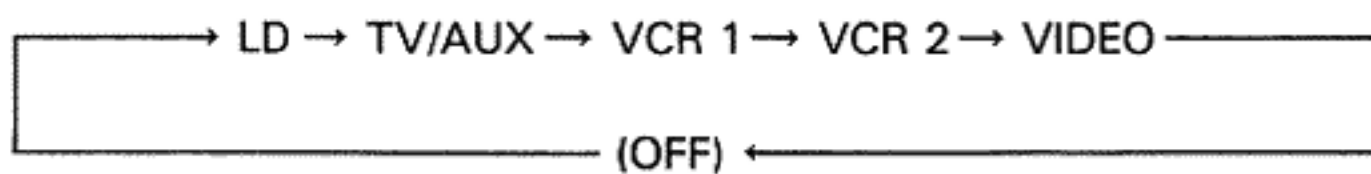

Even when listening to an audio component (record player, tuner, etc.), this button can be used to perform video recording and playback while continuing to listen to the audio component playback.

In the OFF position, there is no video signal from the MONITOR OUT jacks.

⑨ SUBSONIC button/indicators

When the button is pressed to the ON position, the indicator lights and the subsonic filter acts to cut out all frequencies below 17 Hz.

⑩ PHONO SELECTOR button/indicators

Set in accordance with the type of cartridge used on your record player (the corresponding indicator will light).

[MM]: Set here when using a moving magnet cartridge, or a high-output (1 mV or more) moving coil (MC) cartridge.

[MC]: Set here when using a moving coil cartridge.

⑪ DIRECT button/indicator

Use this to listen to the audio signal without routing it through subsonic, tone control (BASS, TREBLE), or balance control circuitry.

NOTE:

When the DIRECT button is in the ON position, the TAPE 2 MONITOR button and SUBSONIC button do not operate.

⑫ Tone controls

[BASS]: Use to adjust low frequency sounds.

The central [0] indicates the standard (flat) position. When the control is rotated to the right, low-frequency sounds are augmented; when rotated to the left, low-frequency sounds are attenuated.

[TREBLE]: Use to adjust high-frequency sounds.

The central [0] indicates the standard (flat) position. When the control is rotated to the right, high-frequency sounds are augmented; when rotated to the left, high-frequency sounds are attenuated.

⑬ BALANCE control

Normally leave in the center position. Use to adjust the balance of sound from right and left channels.

⑭ MUTING button/indicator

Use to temporarily cut the sound. The muting function is on when the MUTING indicator lights. Press the button again to turn the muting function off and return the sound volume to the normal level.

NOTE:

When listening at high volume levels, even if you switch MUTING ON, you will still hear a faint sound.

REAR PANEL

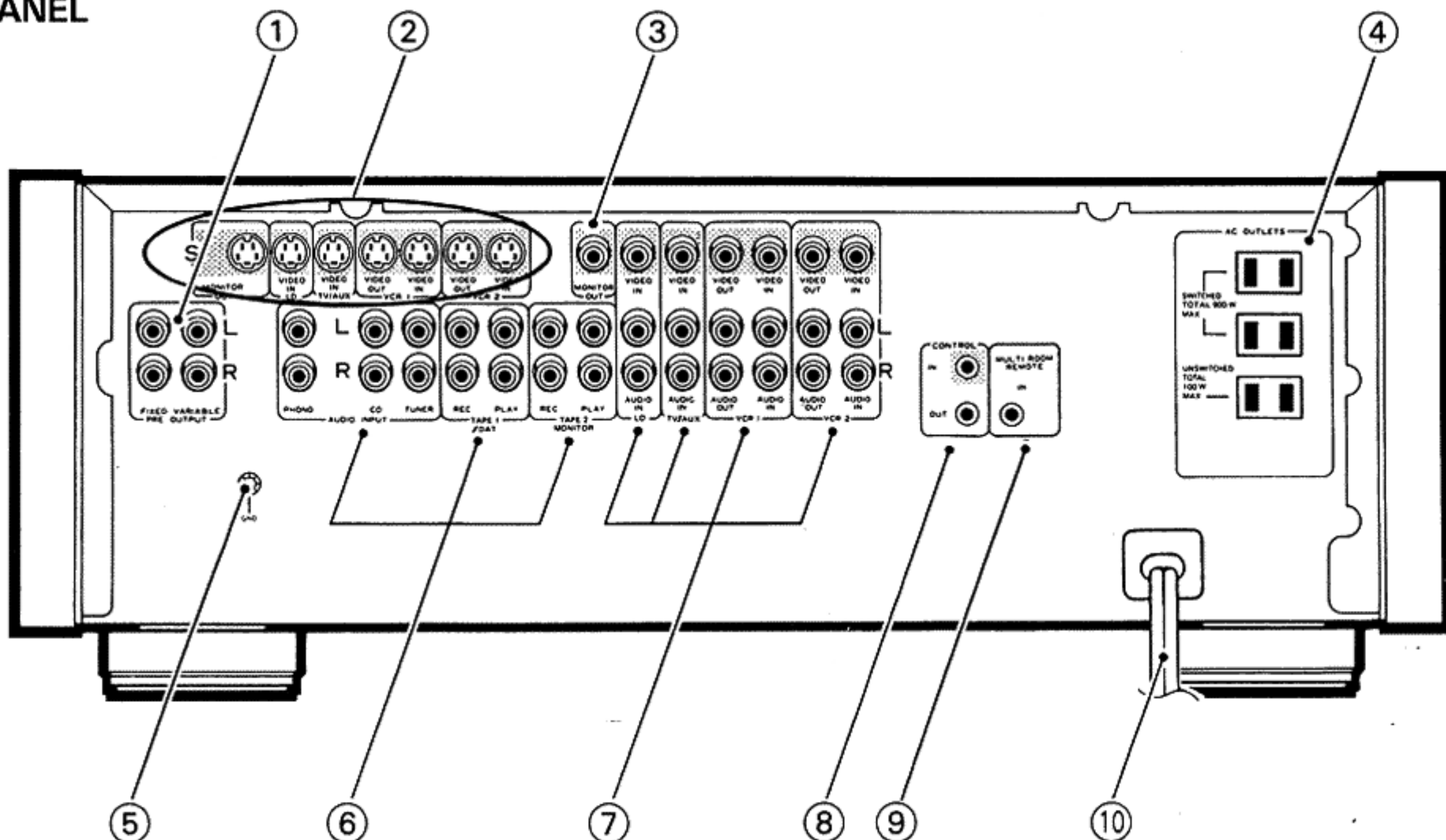

① **PRE OUTPUT terminals**

Connect to the power amplifier or surround processor input terminals.

FIXED: The output level of the signal is fixed, regardless of this unit's VOLUME CONTROL setting.

Connect to a surround processor with volume control capability.

VARIABLE: Adjust the output level of the signal with this unit's VOLUME CONTROL.

When using with a power amplifier, connect to this terminal.

When using in combination with a Pioneer M-72 stereo power amplifier, set the M-72's INPUT LEVEL control to MAX, and adjust volume level with this unit's VOLUME CONTROL.

② **S VIDEO terminals**

When used in conjunction with VCR 1, VCR 2, LaserDisc player or monitor TV equipped with S video terminals, connect to these terminals.

③ **MONITOR OUT terminal**

This terminal outputs the video playback picture from the video components connected to this unit. Connect to the video input terminal of a monitor TV or television set.

④ **AC OUTLETS**

SWITCHED TOTAL 900 W MAX

Power supplied through these outlets is turned on and off by this equipment's POWER switch. Total electrical power consumption of commented equipment should not exceed 900 W.

With a switched AC outlet, you can connect a separately sold M-72 power cord.

UNSWITCHED TOTAL 100 W MAX

Power flows continually to this outlet, regardless of whether this equipment is switched ON or OFF. Electrical power consumption of the connected equipment should not exceed 100 W.

NOTE:

- *This unit should be disconnected by removing the power plug from the wall socket when not in regular use, e.g. when on vacation.*
- *Do not connect appliances with high power consumption such as heaters, irons, or television sets to these AC OUTLETS in order to avoid overheating and fire risk.*
This can cause the control amplifier to malfunction.

CAUTION: DO NOT CONNECT TV SET OR MONITOR

⑤ **Ground (GND) terminal**

Connect to the ground terminal of your turntable.

⑥ **Audio components terminals**

- [PHONO]: Turntable.
- [CD]: Compact disc player.
- [TUNER]: FM/AM Tuner.
- [TAPE 1/DAT]: Cassette deck 1 (first deck) or DAT.
PLAY: For playback (connect to the tape deck's PLAY terminals).
REC: For recording (connect to the tape deck's REC terminals).
- [TAPE 2 MONITOR]: Cassette deck 2 (second deck).
PLAY: For playback. Connect to the cassette deck PLAY terminals.
REC: For recording. Connect to the cassette deck REC terminal.

⑦ **Video components terminals**

Connect to the video and audio terminals of the video components you plan to use.

- [LD]: LaserDisc player.
- [TV]: TV Tuner.
- [VCR 1]: Video cassette recorder 1 (first unit).
IN: For input. Connect to the VCR's video and audio output terminals.
OUT: For output. Connect to the VCR's video and audio input terminals.
- [VCR 2]: Video cassette recorder 2 (second unit).
IN: For input. Connect to the VCR's video and audio output terminals.
OUT: For output. Connect to the VCR's video and audio input terminals.

⑧ **CONTROL terminals**

- IN: Use a control cord to connect when performing remote operations using this unit's remote control unit in conjunction with the remote sensor on the Pioneer component display.
- OUT: The control signal received at the amplifier's signal sensor from the remote control unit is output here to other components. Use a control cord to connect to other components when controlling those components with this remote control unit.

NOTE:

Control connections can be performed only when using Pioneer components bearing the SR mark.

⑨ **MULTI-ROOM REMOTE IN terminals**

Connect the multi-room remote control unit (MR-100; sold separately) to this terminal. You can operate this unit by remote control through the MR-100. It is convenient when this unit is located a separate room.

⑩ **Power cord**

Connect to a household wall outlet, or the power outlet of an audio timer.

OPERATIONS 1 (Basic Operation)

TO PLAY BACK A CONNECTED COMPONENT

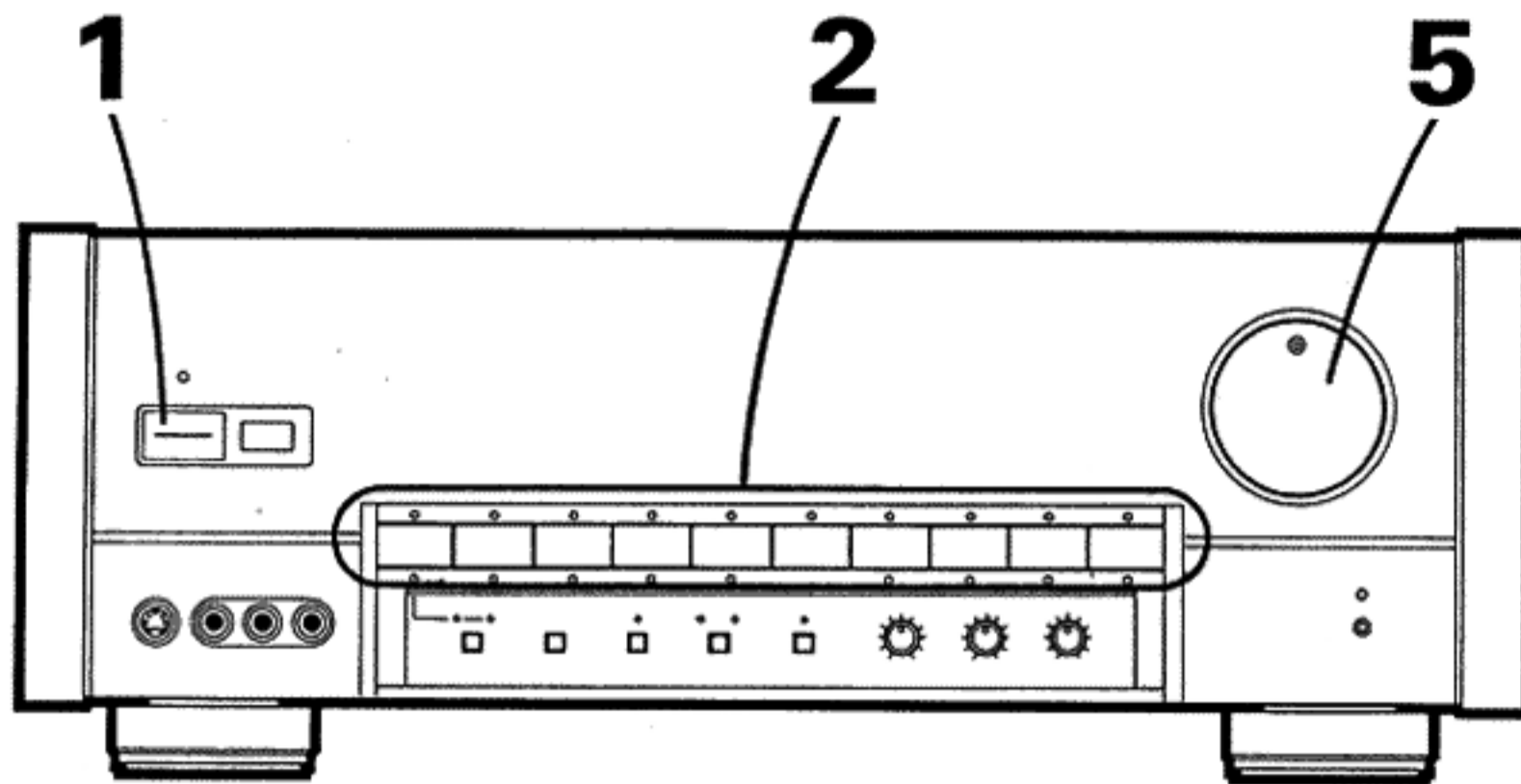

1. Turn on the power to the C-72 and to your power amplifier.

If your power amplifier has an input selector, set it to amplify the signal from the C-72.

NOTE:

Muting operates for about eight seconds directly after the power has been switched on, so there is no sound for that period.

2. Set the audio input selector or the video input selector to the component to be played back.

[For Audio Components]

Set so that the indicator above the button lights.

- To listen to compact discs.
Press [CD].
- To listen to records.
Press [PHONO].
Set the PHONO SELECTOR button to the type of cartridge used (MM or MC).

NOTE:

When the input selector is switched to PHONO from a position other than PHONO, muting operates for about eight seconds and there is no sound.

- To listen to FM/AM radio broadcasts.
Press [TUNER].
- To playback cassette deck 1 or DAT.
Press [TAPE 1/DAT].
- To playback cassette deck 2.
Press [TAPE 2 MONITOR]. At this time, be sure DIRECT is OFF.

[For video components]

Set so that the indicators (red) above the button light.

- For LaserDisc playback.
Press [LD].
- To use the TV tuner.
Press [TV/AUX].
- For VCR 1 playback.
Press [VCR 1].
- For VCR 2 playback.
Press [VCR 2].
- For playback on the component connected to the front panel VIDEO INPUT terminal.
Press [VIDEO].

NOTE:

When playing back components other than cassette deck 2, set TAPE 2 MONITOR to the OFF position (indicator goes out)

3. Turn on the power to the component to be used.

When playing back a video component, also turn on the power to your monitor TV.

4. Operate the playback components to begin playback.

5. Adjust the sound volume with the VOLUME CONTROL.

SUBSONIC FILTER

In the event of low-frequency noise arising from such causes as record warp, set the SUBSONIC filter to the ON position (the indicator lights). The subsonic filter will be applied to cut out the unwanted low-frequency noise.

TONE CONTROL

To adjust the tone of the playback sound, use the BASS, TREBLE controls to adjust the tone as desired.

When using the tone control, switch DIRECT OFF (the indicator goes out).

DIRECT

When you press the DIRECT button, the indicator lights, and you hear a sound that has not been affected by balance, subsonic filter, or tone control (BASS, TREBLE) circuitry. This enables faithful reproduction of an original high-quality sound.

TAPE RECORDING

When the REC SELECTOR is OFF, tape recording is not possible. Either switch to SOURCE or select a component. With the REC SELECTOR in the OFF position, there is no output from the TAPE 1/DAT REC, TAPE 2 MONITOR REC, VCR 1 OUT and VCR 2 OUT jacks.

Recording a source selected with the input selector buttons.

You can record on TAPE 1/DAT if you select a SOURCE with the REC SELECTOR (Except when TAPE 2 MONITOR is ON). You can also record a source selected with the input selector buttons on a cassette deck connected to the TAPE 2 MONITOR terminals.

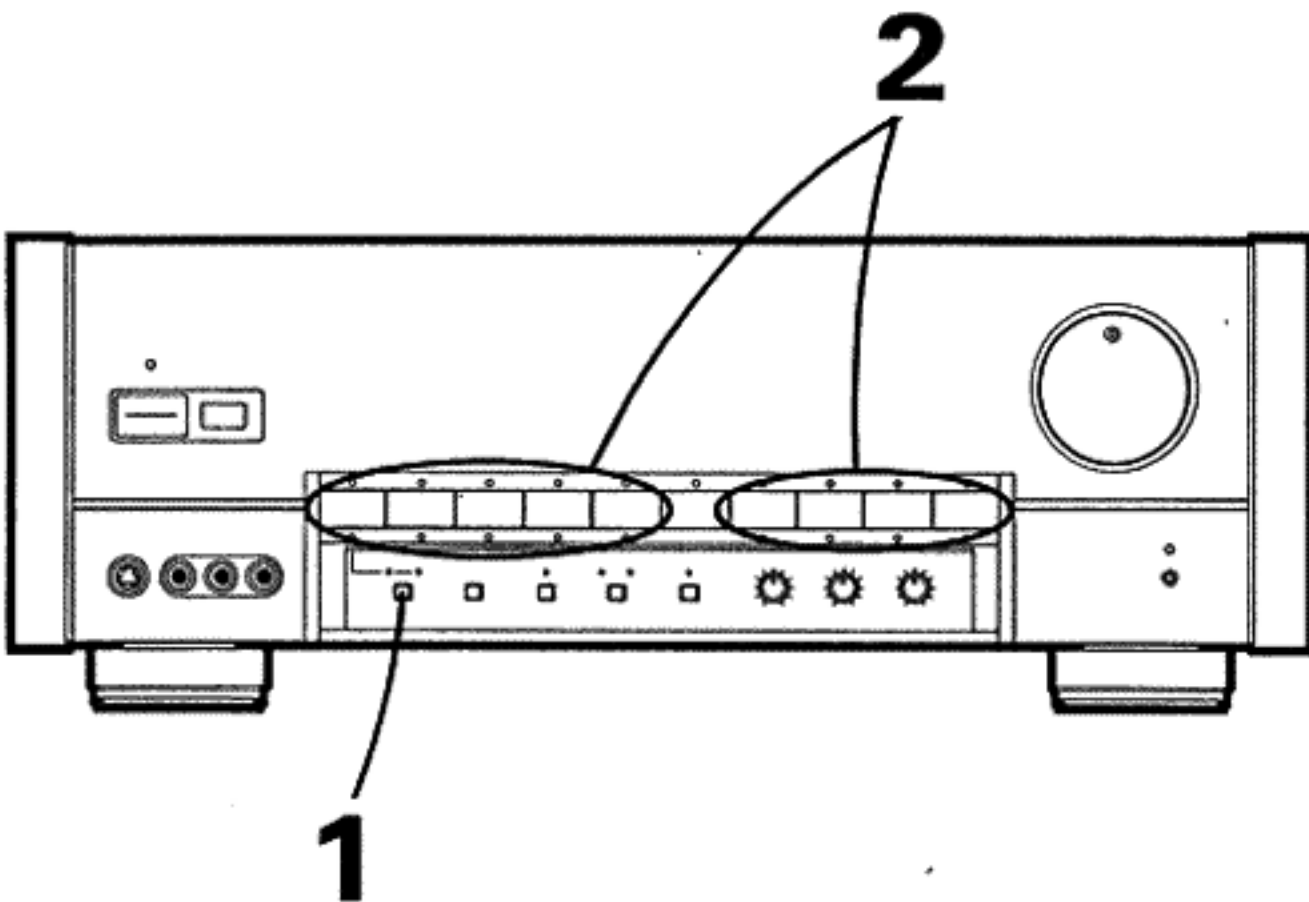

1. Press the REC SELECTOR button, and the SOURCE indicator lights.
2. Select the source with the input selector buttons.
3. Load the cassette deck to be used for recording with a tape to record to.
4. Start recording on the cassette deck.
5. Start play on the component selected with the input selector buttons.

- Refer to deck's operating instructions.
- Adjust amplifier volume and tone if you are listening while recording. (Refer to section on listening to audio sources.)

The recording is not affected by the settings of the VOLUME, BALANCE, TREBLE, or BASS controls.

NOTE:

- When the REC SELECTOR set to SOURCE, and you switch the input selector to PHONO, muting is applied for approximately 8 seconds to TAPE 1/DAT REC, TAPE 2 MONITOR REC, VCR 1 OUT and VCR 2 OUT.
- With the REC SELECTOR set to SOURCE, and the input selector set to PHONO, when the DIRECT button is turned ON/OFF, muting is applied for approximately 8 seconds to TAPE 1/DAT REC, TAPE 2 MONITOR REC, VCR 1 OUT and VCR 2 OUT.

Recording a source not selected with the input selector buttons.

You can record a different source than that selected with the input selector buttons on TAPE 1/DAT. For example, you can listen to a radio broadcast while recording a CD.

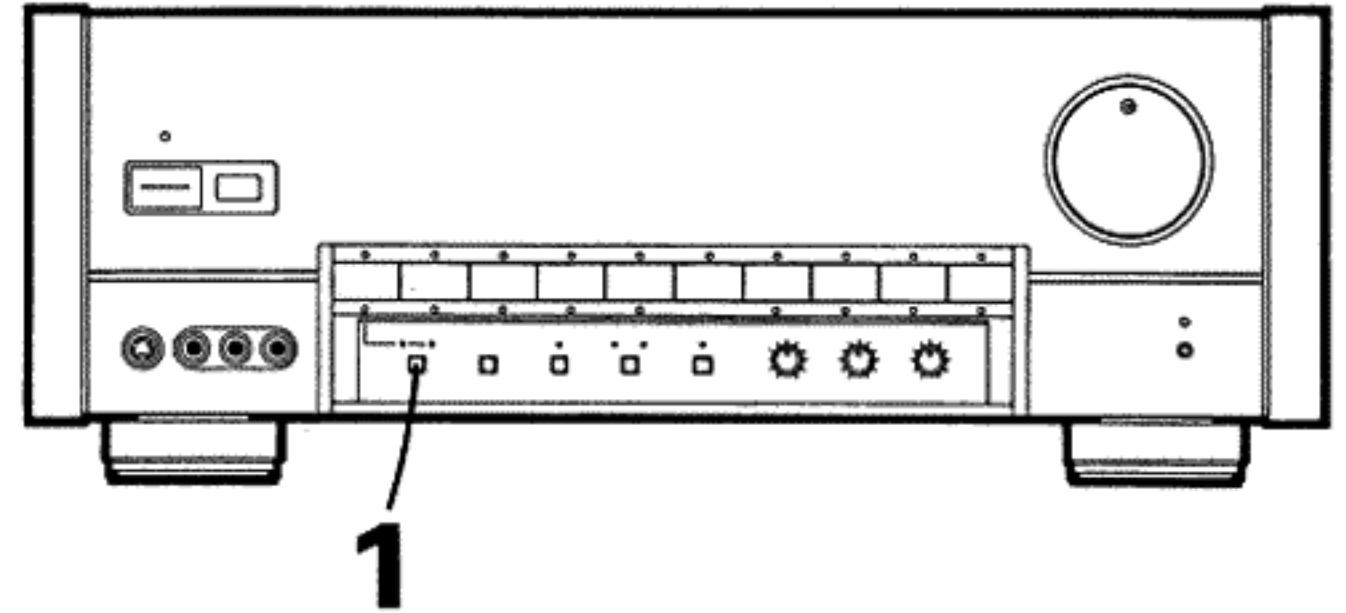

1. Press the REC SELECTOR button, and select a recording source.
 - The indicator under the input selector buttons lights to show the selected component.
2. Load the TAPE 1/DAT cassette deck with a tape to record to.
3. Start recording on the cassette deck.
4. Start play on the component selected with the REC SELECTOR button.
 - Refer to deck's operating instructions.

NOTE:

- When using the REC SELECTOR to record on TAPE 1/DAT, don't select TAPE 1/DAT with the input selector.
- When switching the REC SELECTOR from CD to PHONO, muting is applied for approximately 8 seconds to TAPE 1/DAT REC, TAPE 2 MONITOR REC, VCR 1 OUT and VCR 2 OUT.
- With the REC SELECTOR set to PHONO, when the DIRECT button is turned ON/OFF, muting is applied for approximately 8 seconds to TAPE 1/DAT REC, TAPE 2 MONITOR REC, VCR 1 OUT and VCR 2 OUT.

AUDIO TAPE COPYING

Copying from TAPE 1/DAT to TAPE 2 MONITOR

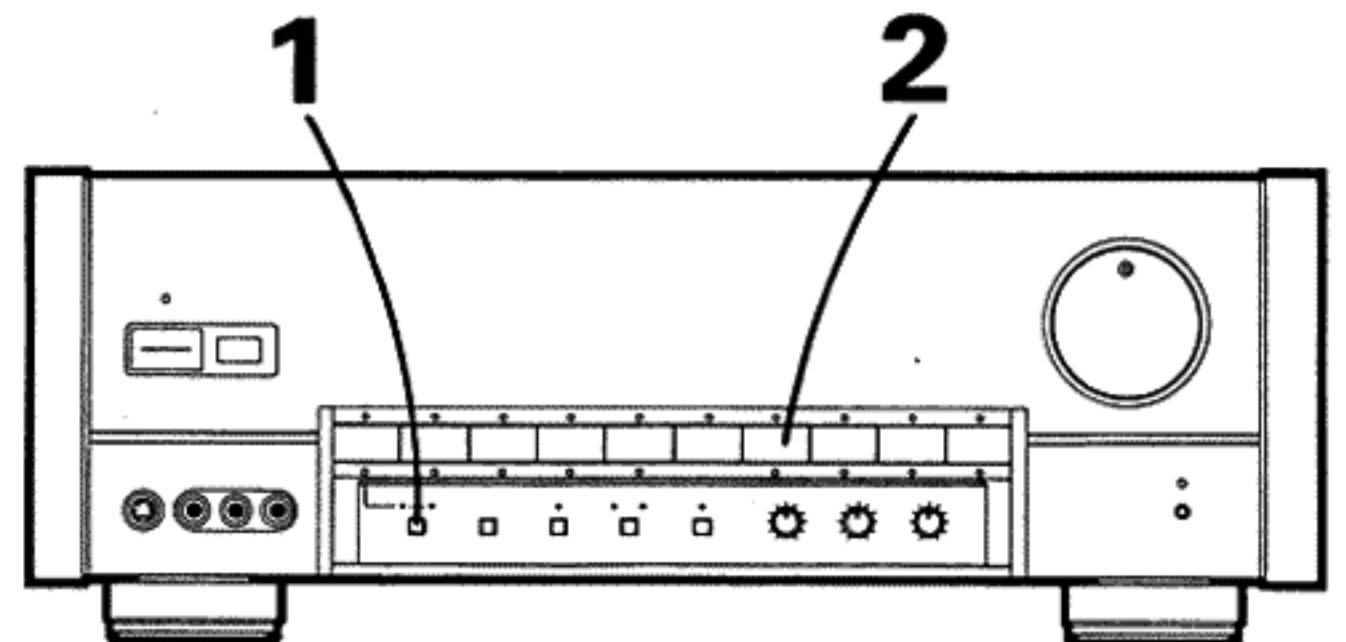

1. Press the REC SELECTOR button lights the SOURCE indicator.
2. Press the input selector button marked TAPE 1/DAT.
3. Load the TAPE 1/DAT cassette deck with the tape you want to copy.
4. Load the TAPE 2 MONITOR cassette deck with a tape to copy to.
5. Start recording on the TAPE 2 MONITOR cassette deck.
6. Start playback on the TAPE 1/DAT cassette deck.

Copying from TAPE 2 MONITOR to TAPE 1/DAT.

Be sure to turn off the DIRECT button.

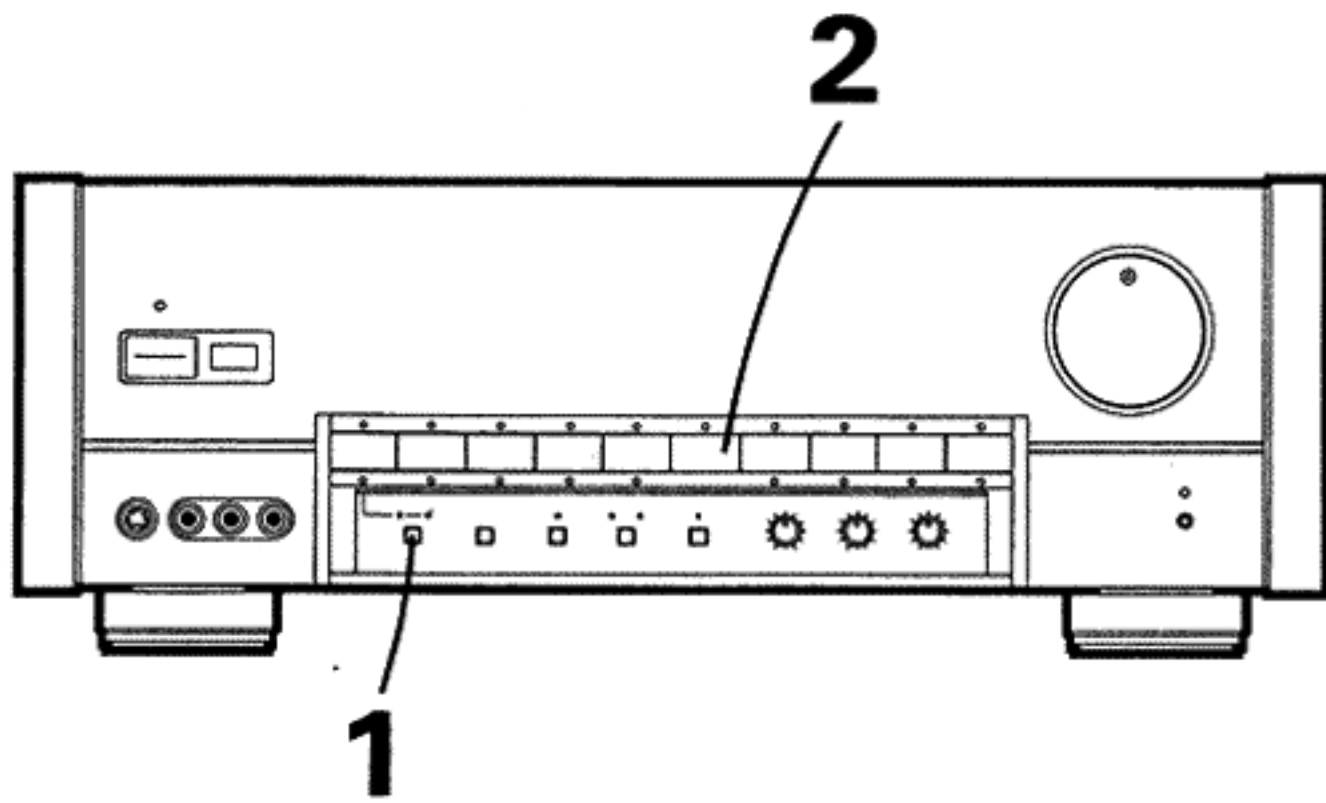

1. Press the REC SELECTOR button lights the SOURCE indicator.
2. Press the input selector button marked TAPE 2 MONITOR.
3. Load the TAPE 2 MONITOR cassette deck with the tape you want to copy.
4. Load the TAPE 1/DAT cassette deck with a tape to copy to.
5. Start recording on the TAPE 1/DAT cassette deck.
6. Start playback on the TAPE 2 MONITOR cassette deck.

RECORDING ON VIDEO TAPE

When the REC SELECTOR is OFF, video tape recording (audio, video) is not possible. Switch to SOURCE, or select a component.

Recording a source selected with the Video input selector buttons.

You can record a source selected with the Video input selector buttons on either VCR 1 or VCR 2. When you have selected VCR (1, 2), no signal is output from VCR OUT terminals with the same number.

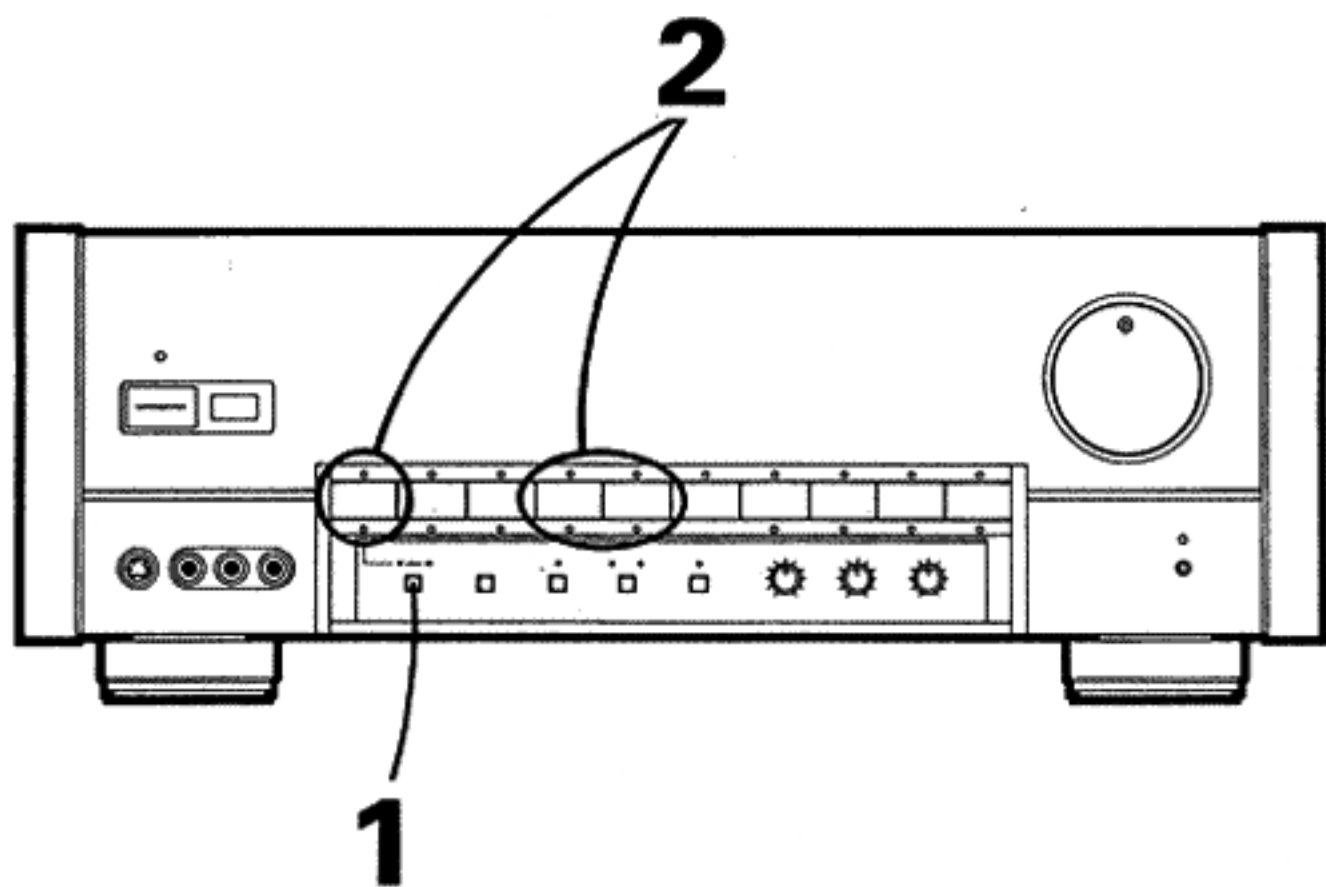

1. Press the REC SELECTOR button, and the SOURCE indicator lights.
2. Select a source with the Video input selector buttons.
3. Load VCR 1 or VCR 2 with a tape to record to.
4. Start recording on the VCR.
 - For VCR 1 (or 2), select a line input (external input).
 - Refer to VCR's operating instructions.
5. Start play on the component selected with the input selector buttons.

Recording a source not selected with the input selector buttons.

You can record a different source than that selected with the input selector buttons on either VCR 1 or VCR 2.

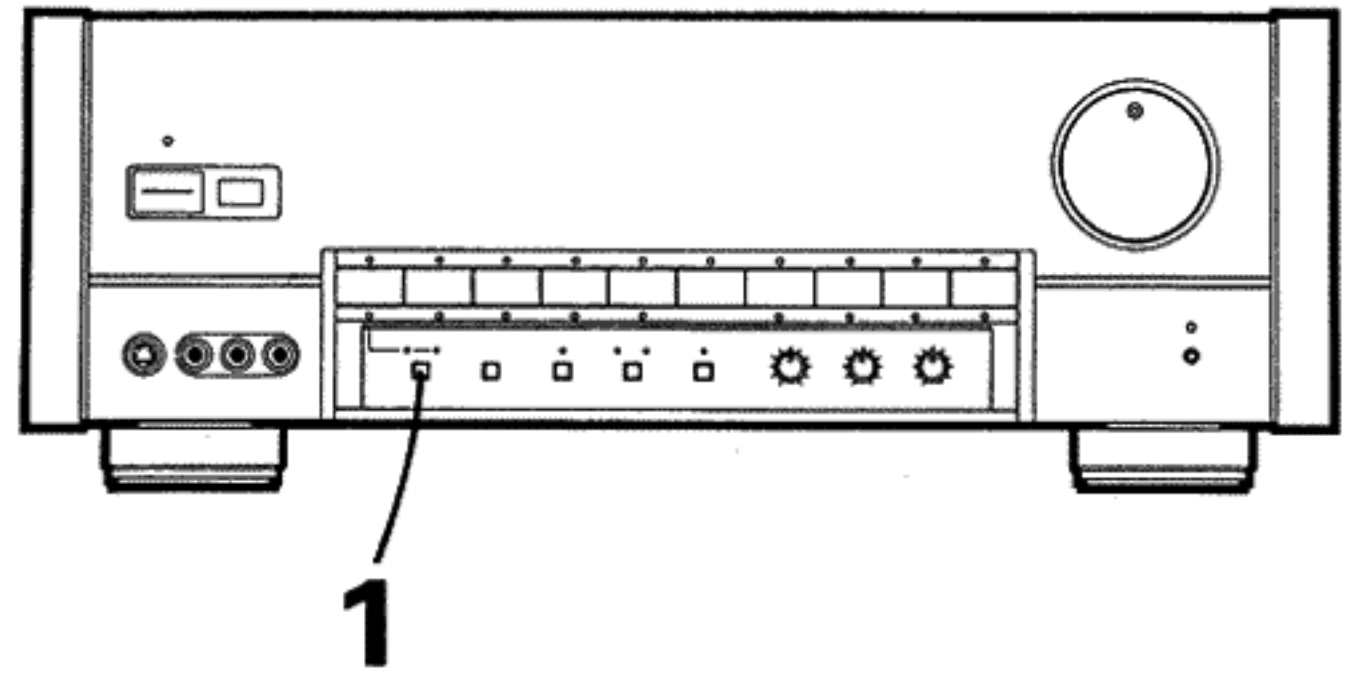

1. Press the REC SELECTOR button, and select a recording source.
 - The indicator under the input selector buttons lights to show the selected component.
2. Load VCR 1 or VCR 2 with a tape to record to.
3. Start recording on the VCR.
 - For VCR 1 (or 2), select a line input (external input).
 - Refer to deck's operating instructions.
4. Start play on the Video component selected with the REC SELECTOR button.

COPYING VIDEO TAPES

• Copying from VCR 1 to VCR 2

Using the same procedure as in "RECORDING ON VIDEO TAPE," select VCR 1 as the source, and VCR 2 for the recording deck.

• Copying from VCR 2 to VCR 1

Using the same procedure as in "RECORDING ON VIDEO TAPE," select VCR 2 as the source, and VCR 1 for the recording deck.

USING THE VIDEO SIGNAL SELECTOR

Using VIDEO SIGNAL SELECTOR button you can change the video source without changing the audio source. You can listen to the LD while watching the VCR picture.

The yellow indicator above the input selector lights to show the component selected with the VIDEO SIGNAL SELECTOR button.

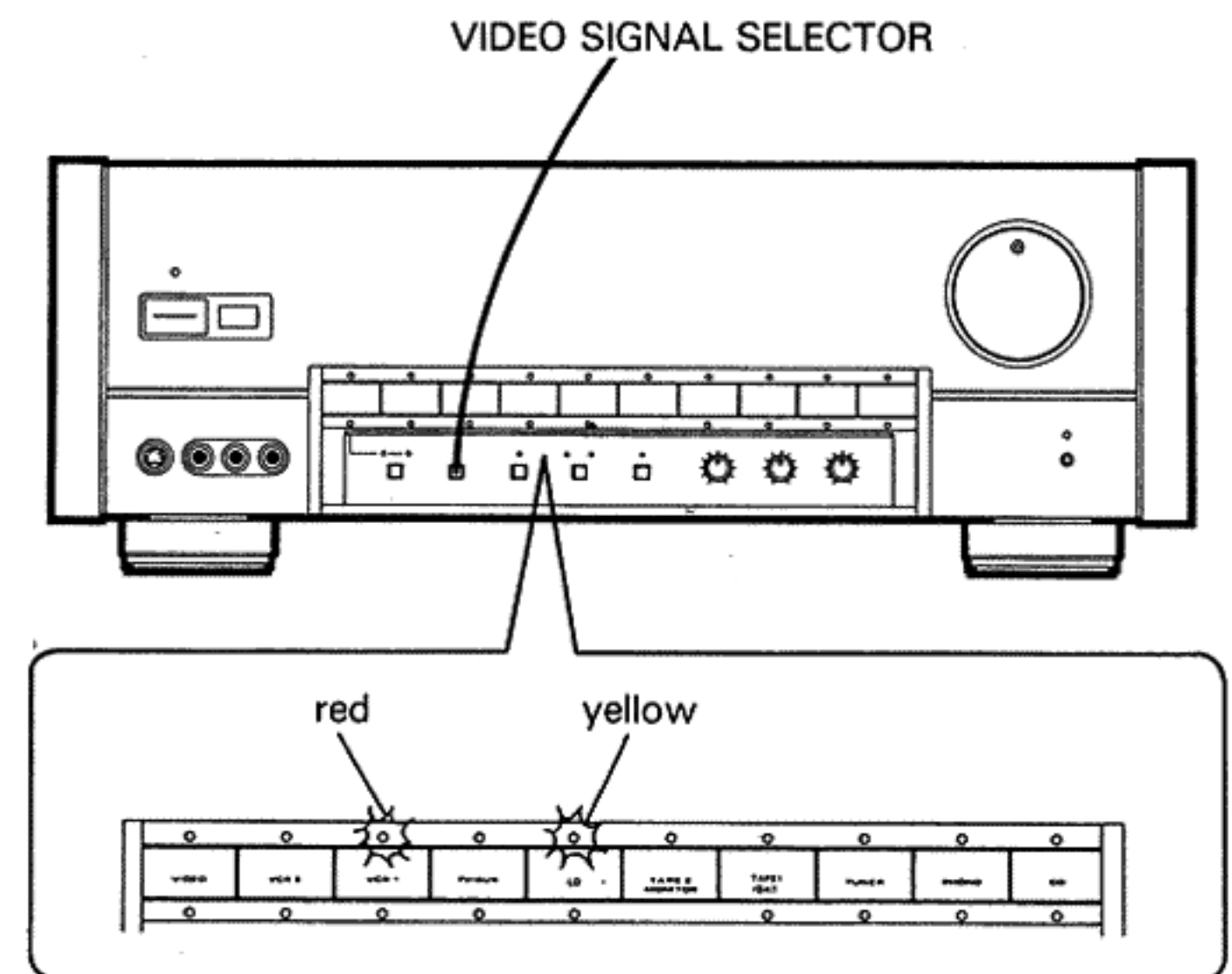

NOTE:

Whenever using this button, set your VCR to the pause mode. If the video signal selector is switched during video recording (when tape is running), the recorded picture and sound may be temporarily disrupted at the time of switching (this depends on the VCR used).

OPERATIONS 2 (Applications)

EXPANSION TO A SURROUND SYSTEM

Normal stereo playback is based on three-dimensional sound from the front (speakers) direction only. In fact, however, when listening to an actual live concert at a concert hall or theater, sound is heard not only from the front, but it envelops the body from all sides, reverberating off the high ceiling and wide wall area. Such sound qualities form elements of the sense of "presence" and "spatial breadth" felt at such live concerts. The surround system is a means of reproducing this sense of presence and breadth.

To enable connection to a surround processor, the main unit is equipped with FIXED PRE OUTPUT jacks. Connect them to the surround processor's input jacks.

[Operations]

Set the input selector to the playback component.

[CONNECTION EXAMPLE]

For details concerning connection to surround processors and other components (such as a power amp), refer to the components' operating instructions.

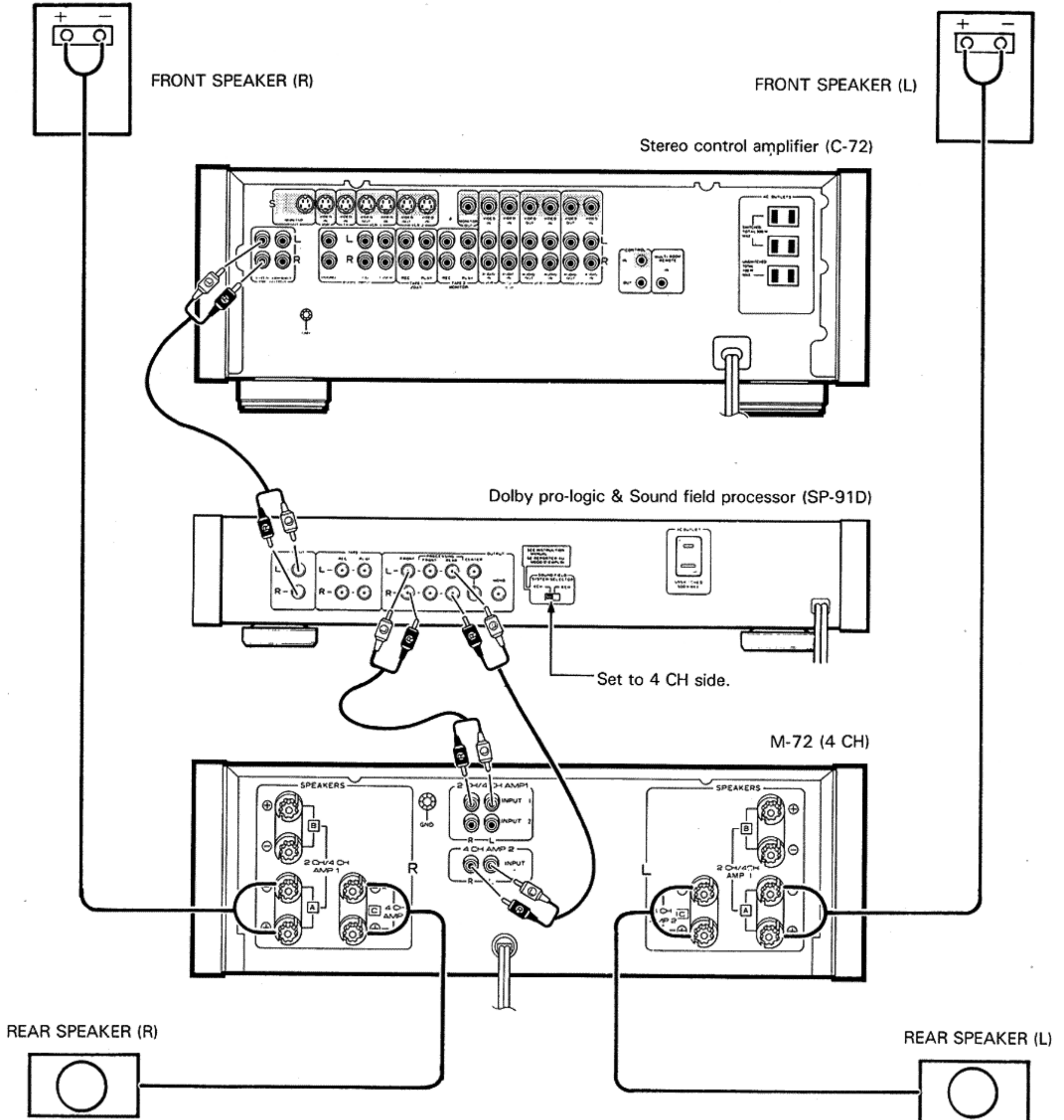

SYSTEM CONTROL

Unified system control can be performed when using Pioneer components equipped with control input terminals, and bearing the **SR** mark.

[Connections]

Connect the control input and output terminals in order.
Be sure to connect properly, since system control cannot be performed when video or audio cables are not connected.

[Operation]



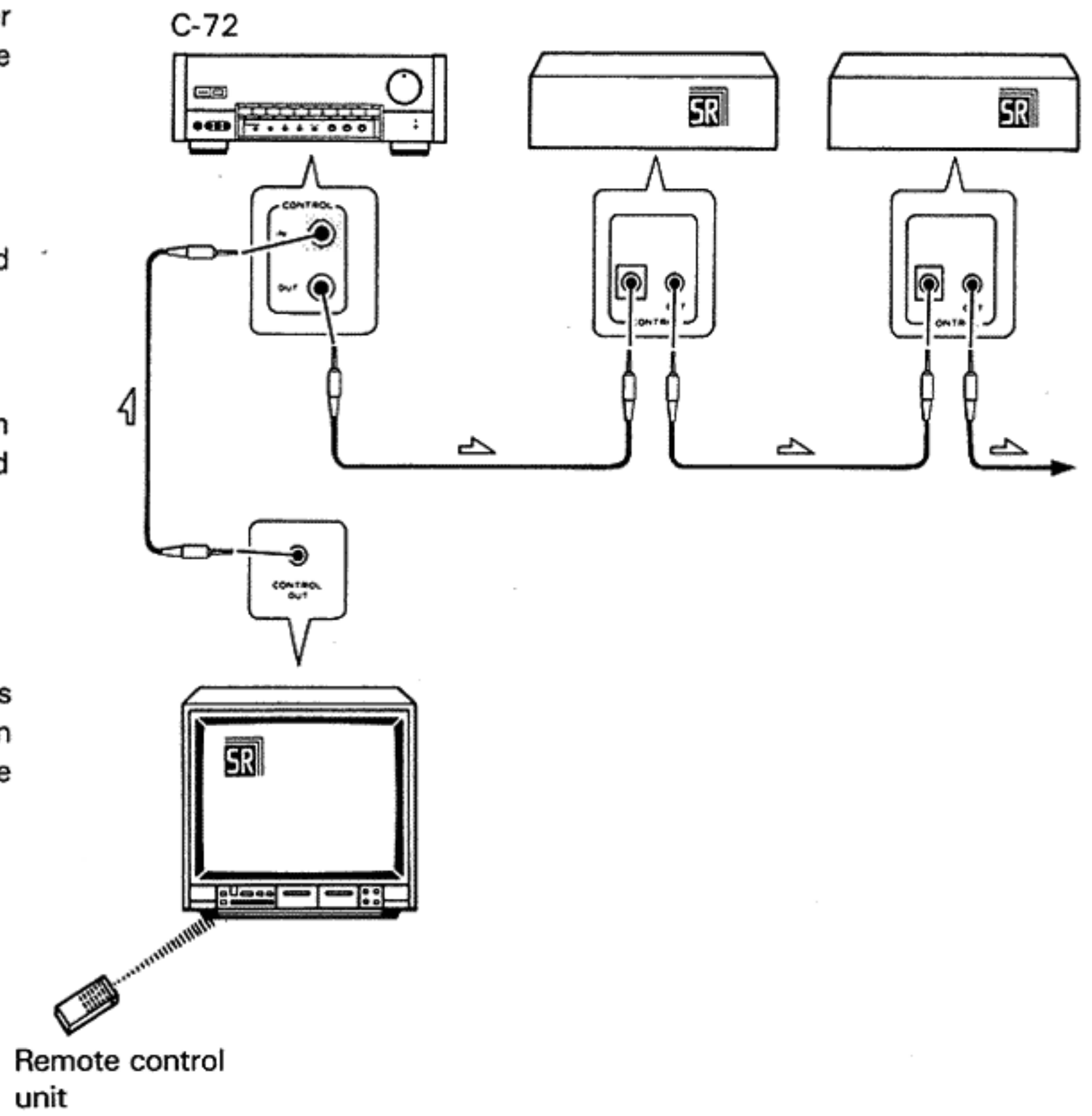

The remote control unit furnished with the C-72 can be used to perform remote control of the major functions of the control-connected components.

When the television's CONTROL OUT is connected to the amplifier's CONTROL IN, point the remote control unit at the remote sensor on the television set when performing remote operations. Be sure that the television set's main power switch is ON.

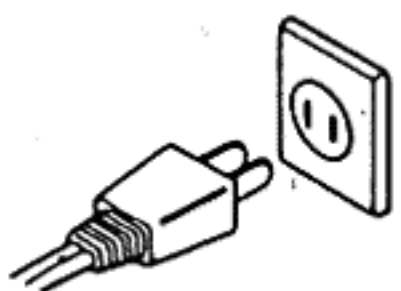
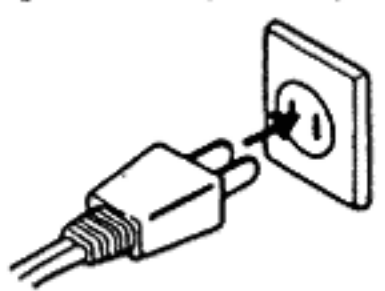

TROUBLESHOOTING

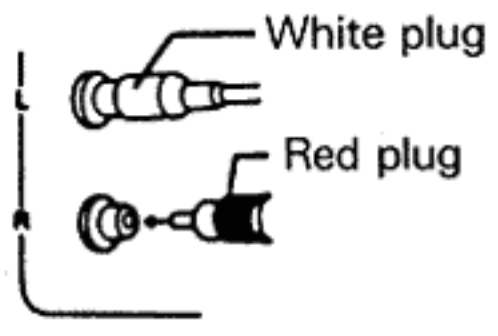
Incorrect operations are often mistaken for trouble and malfunctions. If you think that there is something wrong with this component, check the points below. Sometimes the trouble may lie in another component. Investigate the other components and electrical appliances being used. If the trouble cannot be rectified even after exercising the checks listed below, ask your nearest PIONEER authorized service center or your dealer to carry out repair work.

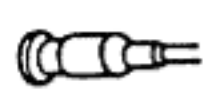
Symptom	Cause	Remedy	
No Power.	<ul style="list-style-type: none"> • Power plug is disconnected from outlet.  <ul style="list-style-type: none"> • If the power plug is connected to the switched auxiliary outlet of another component, the power is turned OFF to the other component. 	<ul style="list-style-type: none"> • Connect plug securely into power outlet.  <ul style="list-style-type: none"> • Turn on the power to the other component. 	
No sound.	<ul style="list-style-type: none"> • A short pin plug is connected to the REC, AUDIO OUT terminal. • Connection cords are disconnected from terminals, or connected incorrectly.  <ul style="list-style-type: none"> • Terminals and/or connecting cord plugs are dirty. • The MUTING switch is set to ON. 	<ul style="list-style-type: none"> • Remove short pin plug. • Connect cords securely.  <ul style="list-style-type: none"> • Clean plugs and terminals. • Set the switch to OFF. 	
	(For tape playback)	<ul style="list-style-type: none"> • Cassette deck is being operated incorrectly. 	<ul style="list-style-type: none"> • Consult the operating instructions for the cassette deck used.
	(In other cases)	<ul style="list-style-type: none"> • The input selector switch is not set to the playback component. • Other components are being operated incorrectly. 	<ul style="list-style-type: none"> • Set the switch correctly. • Consult the operating instructions for the other components.
No picture	<ul style="list-style-type: none"> • A short pin plug is connected to the VIDEO OUT terminal. • Connection cords are disconnected from terminals, or connected incorrectly.  <ul style="list-style-type: none"> • Terminals and connection cord pin-plugs are dirty. • Input selector or video signal selector is not set to the playback component. 	<ul style="list-style-type: none"> • Remove short pin plug. • Connect correctly and securely.  <ul style="list-style-type: none"> • Clean terminals and pin plugs. • Set correctly. 	
	<ul style="list-style-type: none"> • Other components are being operated incorrectly. 	<ul style="list-style-type: none"> • Consult the operating instructions for the other components. 	
No sound from one speaker.	<ul style="list-style-type: none"> • Connection cords are disconnected from one side. • The balance control is set too far to one side. 	<ul style="list-style-type: none"> • Connect cords securely. • Set the control to the center position. 	

Symptom	Cause	Remedy
<p>The remote control unit does not work. (Other components cannot be operated.)</p>	<ul style="list-style-type: none"> • There are no batteries in the remote control unit. • The remote control sensor is not receiving any signals. • The remote control unit is not transmitting any signals. • The remote control cord is not connected. • A fluorescent light is shining on the remote sensor window. 	<ul style="list-style-type: none"> • Load the remote control unit with batteries. • Operate the remote control unit within a range of 7 meters an angle of 30 degrees. • Press the remote control RESET switch. • Connect correctly. • Move so fluorescent light does not shine directly on amplifier front panel remote sensor window.

Abnormal functioning of this unit may be caused by lightning, static electricity, or other external interface. To restore normal operation, turn the power standby and then on again, or unplug the AC power cord and then plug it in again.

SPECIFICATIONS

Amplifier Section

Rated output	
20 Hz — 20 kHz, 0.01 % 10 k Ω	7 V
Total harmonic distortion	
20 Hz — 20 kHz, 1 V	0.002 %
Input terminals (sensitivity/impedance)	
PHONO MM	2.5 mV/50 k Ω
PHONO MC	250 μ V/100 Ω
CD, TUNER, TAPE PLAY, AUX	150 mV/50 k Ω
Output terminals (output level/output impedance)	
TAPE REC	150 mV/2.2 k Ω
PRE OUT	1 V/1 k Ω
Frequency response	
PHONO MM 20 Hz — 20 kHz	\pm 0.2 dB
PHONO MC 20 Hz — 20 kHz	\pm 0.3 dB
CD, TUNER, TAPE PLAY, AUX, 1 Hz — 150 kHz	\pm $\frac{0}{3}$ dB
Tone control (Volume control set at -40 dB position)	
BASS	\pm 8 dB, 100 Hz
TREBLE	\pm 8 dB, 10 kHz
Filter	
SUBSONIC	17 Hz, -12 dB/oct
MUTING	$-\infty$ dB
SN ratio (short-circuit, A network)	
PHONO MM	93 dB (5 mV)
PHONO MC	76 dB (500 μ V)
CD, TUNER, TAPE PLAY, AUX	106 dB

Video section

Video (Base Band)	
Input terminals (Output level/impedance)	
LD, VCR 1, 2, VIDEO, TV/AUX	1 Vp-p/75 Ω unbalanced
Output terminals (Output level/impedance)	
VCR 1, 2, REC MONITOR	1 Vp-p/75 Ω unbalanced
DG	2 %
DP	2 $^{\circ}$
Frequency response 10 Hz — 10 MHz	\pm $\frac{0}{3}$ dB
Noise level	-60 dB or less

S type terminal

Input terminal (luminance signals sensitivity/impedance, color signals sensitivity/impedance)	
LD, VCR 1, 2, VIDEO, TV/AUX	1 Vp-p/75 Ω unbalanced 0.286 Vp-p/75 Ω unbalanced
Output terminal (luminance signals output level/impedance, color signals output level/impedance)	
VCR 1, 2, MONITOR	1 Vp-p/75 Ω unbalanced 0.286 Vp-p/75 Ω unbalanced
Luminance signals frequency characteristic 10 Hz — 10 MHz	\pm $\frac{0}{3}$ dB
Noise level (luminance signal)	max. -60 dB

Power section, other

Power requirements	AC 120 V, 60 Hz
Power consumption	30 W
AC outlets	
SWITCHED	TOTAL 900 W MAX
UNSWITCHED	TOTAL 100 W MAX
External dimensions	459 (W) x 417 (D) x 163 (H) mm 18-1/16 (W) x 16-7/16 (D) x 6-7/16 (H) in
Weight	11.3 kg (24 lb 15 oz)

Accessories

Remote control unit	1
Alkaline dry cell batteries (IEC LR03 (AM-4))	4
Templates added	2
Pin-plug cord	1
Cushion spacer	2
Operating Instructions	1

The specifications and design noted above are subject to change without notice, due to improvements.

POWER-CORD CAUTION

Handle the power cord by the plug. Do not pull out the plug by tugging the cord and never touch the power cord when your hands are wet as this could cause a short circuit or electric shock. Do not place the unit, a piece of furniture, etc., on the power cord, or pinch the cord. Never make a knot in the cord or tie it with other cords. The power cords should be routed such that they are not likely to be stepped on. A damaged power cord can cause fire or give you an electrical shock. Check the power cord once in a while. When you find it damaged, ask your nearest PIONEER authorized service center or your dealer for a replacement.

MAINTENANCE OF EXTERNAL SURFACES

- Use a polishing cloth or dry cloth to wipe off dust and dirt.
- When the surfaces are very dirty, wipe with a soft cloth dipped in some neutral cleanser diluted five or six times with water, and wrung out well, and then wipe again with a dry cloth. Do not use furniture wax or cleaners.
- Never use thinners, benzene, insecticide sprays and other chemicals on or near this unit, since these will corrode the surfaces.

PIONEER ELECTRONIC CORPORATION 4-1, Meguro 1-Chome, Meguro-ku, Tokyo 153, Japan

PIONEER ELECTRONICS [USA] INC. 2265 East 220th Street, Long Beach, California 90810, U.S.A.

P.O. BOX 1720, Long Beach, California 90801, U.S.A.

PIONEER ELECTRONICS OF CANADA, INC. 505 Cochrane Drive, Markham, Ontario L3R 8E3, Canada

PIONEER ELECTRONIC [EUROPE] N.V. Keetberglaan 1, 2740 Beveren, Belgium; TEL: 03/750.0511

PIONEER ELECTRONICS AUSTRALIA PTY. LTD. 178-184 Boundary Road, Braeside, Victoria 3195, Australia, TEL: [03] 580-9911